

USER MANUAL

VKP80III

CUSTOM[®]

CUSTOM S.p.A.
Via Berettine 2/B
43010 Fontevivo (PARMA) - Italy
Tel. : +39 0521-680111
Fax : +39 0521-610701
http: www.custom.biz

Customer Service Department:
www.custom4u.it

© 2024 CUSTOM S.p.A. – Italy.
All rights reserved. Total or partial reproduction of this manual in whatever form, whether by printed or electronic means, is forbidden. While guaranteeing that the information contained in it has been carefully checked, CUSTOM S.p.A. and other entities utilized in the realization of this manual bear no responsibility for how the manual is used. Information regarding any errors found in it or suggestions on how it could be improved are appreciated. Since products are subject to continuous check and improvement, CUSTOM S.p.A. reserves the right to make changes in information contained in this manual without prior notification.

The pre-installed multimedia contents are protected from Copyright CUSTOM S.p.A. Other company and product names mentioned herein may be trademarks of their respective companies. Mention of third-party products is for informational purposes only and constitutes neither an endorsement nor a recommendation. CUSTOM S.p.A. assumes no responsibility with regard to the performance or use of these products.

THE IMAGES USED IN THIS MANUAL ARE USED AS AN ILLUSTRATIVE EXAMPLES. THEY COULDN'T REPRODUCE THE DESCRIBED MODEL FAITHFULLY.

UNLESS OTHERWISE SPECIFIED, THE INFORMATION GIVEN IN THIS MANUAL ARE REFERRED TO ALL MODELS IN PRODUCTION AT THE ISSUE DATE OF THIS DOCUMENT.

GENERAL INSTRUCTIONS

CUSTOM S.p.A. declines all responsibility for accidents or damage to persons or property occurring as a result of tampering, structural or functional modifications, unsuitable or incorrect installations, environments not in keeping with the equipment's protection degree or with the required temperature and humidity conditions, failure to carry out maintenance and periodical inspections and poor repair work.

GENERAL SAFETY INFORMATION

Your attention is drawn to the following actions that could compromise the characteristics of the product:

- Read and retain the instructions which follow.
- Follow all indications and instructions given on the device.
- Make sure that the surface on which the device rests is stable. If it is not, the device could fall, seriously damaging it.
- Make sure that the device rests on a hard (non-padded) surface and that there is sufficient ventilation.
- Do not fix indissolubly the device or its accessories such as power supplies unless specifically provided in this manual.
- When positioning the device, make sure cables do not get damaged.
- [Only OEM equipment] The equipment must be installed in a kiosk or system that provides mechanical, electrical and fire protection.
- The mains power supply must comply with the rules in force in the Country where you intend to install the equipment.
- Make sure that there is an easily-accessible outlet with a capacity of no less than 10A closely to where the device is to be installed.
- Make sure the power cable provided with the appliance, or that you intend to use is suitable with the wall socket available in the system.
- Make sure the electrical system that supplies power to the device is equipped with a ground wire and is protected by a differential switch.
- Before any type of work is done on the machine, disconnect the power supply.
- Use the type of electrical power supply indicated on the device label.
- These devices are intended to be powered by a separately certified power module having an SELV, non-energy hazardous output. (IEC60950-1 second edition).
- [Only POS equipment] The energy to the equipment must be provided by power supply approved by CUSTOM S.p.A.
- Take care the operating temperature range of equipment and its ancillary components.
- Do not block the ventilation openings.
- Do not insert objects inside the device as this could cause short-circuiting or damage components that could jeopardize printer functioning.
- Do not carry out repairs on the device yourself, except for the normal maintenance operations given in the user manual.
- The equipment must be accessible on these components only to trained, authorized personnel.
- Periodically perform scheduled maintenance on the device to avoid dirt build-up that could compromise the correct, safe operation of the unit.
- Do not touch the head heating line with bare hands or metal objects. Do not perform any operation inside the printer immediately after printing because the head and motor tend to become very hot.
- Use consumables approved by CUSTOM S.p.A.



THE CE MARK AFFIXED TO THE PRODUCT CERTIFY THAT THE PRODUCT SATISFIES THE BASIC SAFETY REQUIREMENTS.

The device is in conformity with the essential Electromagnetic Compatibility and Electric Safety requirements laid down in Directives 2014/30/EU and 2014/35/EU inasmuch as it was designed in conformity with the provisions laid down in the following Standards:

- EN 55032 (*Electromagnetic compatibility of multimedia equipment - Emission Requirements*)
- EN 55024/EN55035 (*Electromagnetic compatibility of multimedia equipment - Immunity requirements*)
- EN IEC/EN62368-1 (*Audio/video, information and communication technology equipment*)

The device is in conformity with the essential requirements laid down in Directives 2014/53/EU about devices equipped with intentional radiators. The Declaration of Conformity and other available certifications can be downloaded from the site www.custom4u.it.



GUIDELINES FOR THE DISPOSAL OF THE PRODUCT

The crossed-out rubbish bin logo means that used electrical and electronic products shall NOT be mixed with unsorted municipal waste. For more detailed information about recycling of this product, refer to the instructions of your country for the disposal of these products.

- Do not dispose of this equipment as miscellaneous solid municipal waste, but arrange to have it collected separately.
- The re-use or correct recycling of the electronic and electrical equipment (EEE) is important in order to protect the environment and the wellbeing of humans.
- In accordance with European Directive WEEE 2012/19/EU, special collection points are available to which to deliver waste electrical and electronic equipment and the equipment can also be handed over to a distributor at the moment of purchasing a new equivalent type.
- The public administration and producers of electrical and electronic equipment are involved in facilitating the processes of the re-use and recovery of waste electrical and electronic equipment through the organisation of collection activities and the use of appropriate planning arrangements.
- Unauthorised disposal of waste electrical and electronic equipment is punishable by law with the appropriate penalties.
- For the waste sorting of the packaging materials, please check the local waste disposal laws.



The format used for this manual improves use of natural resources reducing the quantity of necessary paper to print this copy.



FCC STATEMENT
(FEDERAL COMMUNICATIONS
COMMISSIONS).

This note is valid only for device bringing FCC trademark.

This device complies with Part 15 of the FCC Rules. Operation is subject to the following conditions:

The devices may not cause harmful interference.
The devices must accept any interference received, including interference that may cause undesired operation.

NOTE: This equipment has been tested and found to comply with the limits for a Class B digital device, pursuant to Part 15 of the FCC Rules. These limits are designed to provide reasonable protection against harmful interference in a residential installation. This equipment generates, uses and can radiate radio frequency energy and, if not installed and used in accordance with the instructions, may cause harmful interference to radio communications. However, there is no guarantee that interference will not occur in a particular installation. If this equipment does cause harmful interference to radio or television reception, which can be determined by turning the equipment off and on, the user is encouraged to try and correct the interference by one or more of the following measures:

Reorient or relocate the receiving antenna.
Increase the separation between the equipment and receiver.
Connect the equipment into an outlet on a circuit different from that to which the receiver is connected.
Consult the dealer or an experienced radio/TV technician for help.

Modifications to this product not authorized by CUSTOM S.p.A. could void the FCC & Industry Canada regulations and negate your authority to operate the product.

This Class B digital apparatus complies with Canadian ICES-003.

Cet appareil numérique de la classe B est conforme à la norme NMB-003 du Canada.

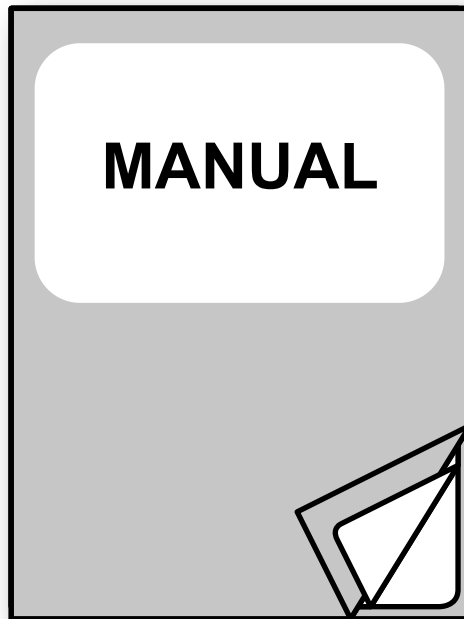

For details on the commands,
refer to the manual with code. **7720000000200**

For further information about the use of "PrinterSet" tool
refer to the manual with code **78200000001800**

TABLE OF CONTENTS

1	INTRODUCTION	9
2	IDENTIFICATION OF THE MODELS	11
3	DESCRIPTION	13
3.1	Box contents	13
3.2	Device components: external views	14
3.3	Device components: internal views	17
3.4	Device labels	18
3.5	Key functions: power up	19
3.6	Key functions: standby	21
3.7	Status messages	22
4	INSTALLATION	23
4.1	Fastening	23
4.2	Connections	25
4.3	Pinout	28
4.4	Driver and SDK	34
5	OPERATION	35
5.1	Cover opening	35
5.2	Adjusting paper width	36
5.3	Adjusting paper width with the paper roll holder (optional)	37
5.4	Adjusting the paper stock with the paper roll holder (optional)	38
5.5	Low paper sensor	39
5.6	Adjusting the alignment sensors	41
5.7	Switch the device ON	44
5.8	Loading the paper roll	47
5.9	Issuing ticket	52
6	CONFIGURATION	61
6.1	Configuration by software	61
6.2	Configuration by keys	63
6.3	Configuration by file	67
6.4	Printhead status	69
6.5	Device status	70
6.6	Communication parameters	71
6.7	Operating parameters	73
6.8	Alignment parameters	76
6.9	Hexadecimal dump	78

7	ALIGNMENT	79
7.1	Enable alignment	80
7.2	Calibration	82
7.3	Alignment parameters	84
7.4	Printing area	87
8	MAINTENANCE	89
8.1	Planning of cleaning operations	89
8.2	Cleaning	90
8.3	Firmware upgrade	94
9	SPECIFICATION	97
9.1	Hardware specifications	97
9.2	Character specifications	101
9.3	Ejector specifications	101
9.4	Device dimensions	102
9.5	Device dimensions with shutter device	103
9.6	Device dimensions with adjustable paper roll holder	104
9.7	Device dimensions with adjustable paper roll holder with inverted paper roll pin	106
9.8	Power supply, power cord and adapter for power supply dimensions	108
9.9	Paper specification	110
9.10	Character sets	112
9.11	True Type fonts	114
10	CONSUMABLES	115
11	ACCESSORIES	117
12	TECHNICAL SERVICE	119



1 INTRODUCTION

This document is divided into sections and chapters. Each chapter can be reached by the index at the beginning of this document. The index can be reached by the button on each page as shown in the diagram below.

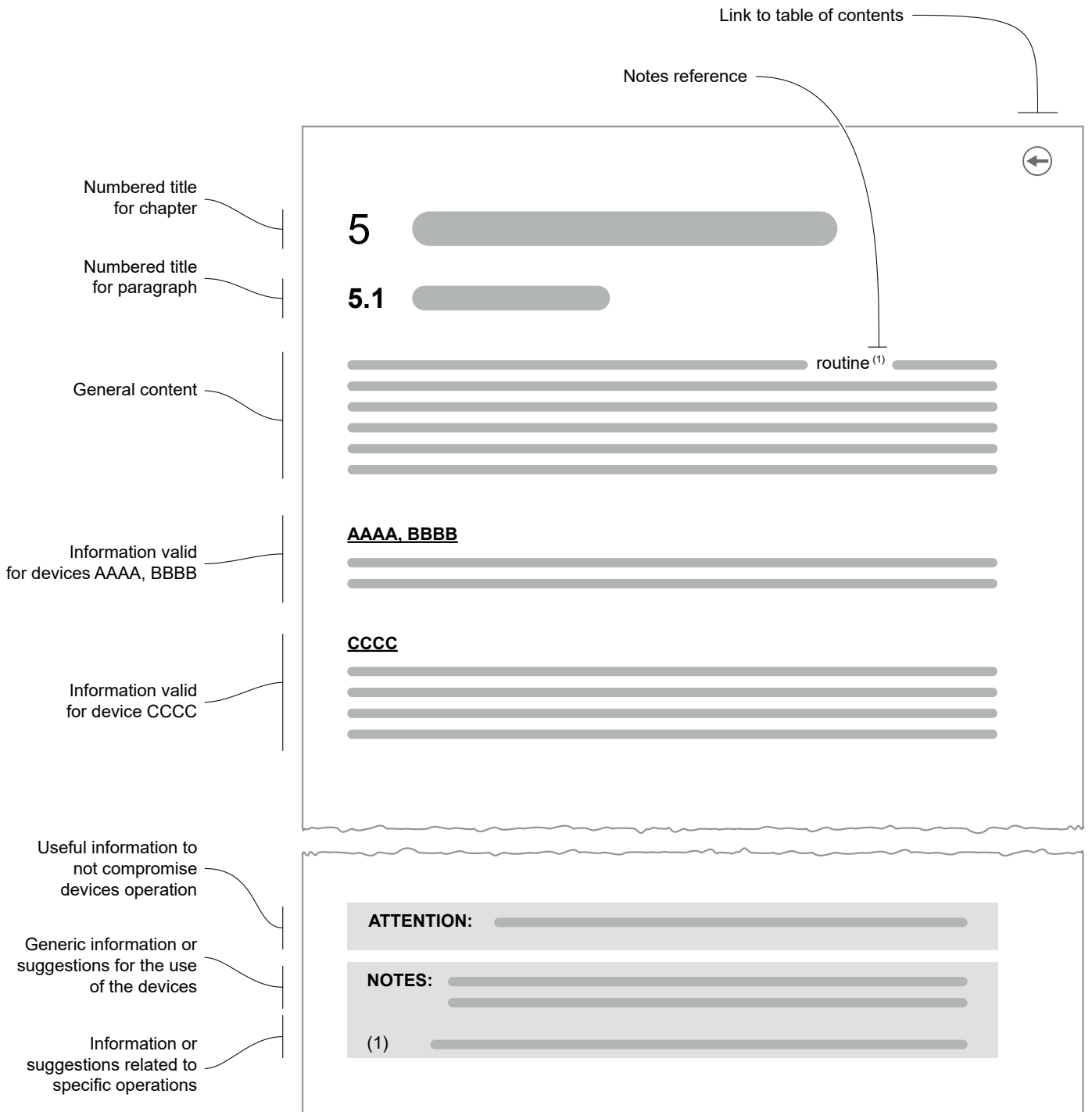





2 IDENTIFICATION OF THE MODELS

NOMENCLATURE	DESCRIPTION
VKP80III RX65 LAT	Model with lateral connectors (RX65 version)
VKP80III RX65 REAR	Model with rear connectors (RX65 version)
VKP80III ETH	Model with lateral connectors and Ethernet port



3 DESCRIPTION

3.1 Box contents

Remove the device from its carton being careful not to damage the packing material so that it may be re-used if the printer is to be transported in the future.

Make sure that all the components illustrated below are present and that there are no signs of damage. If there are, contact Customer Service

1. Documentation (installation instruction)
2. Device

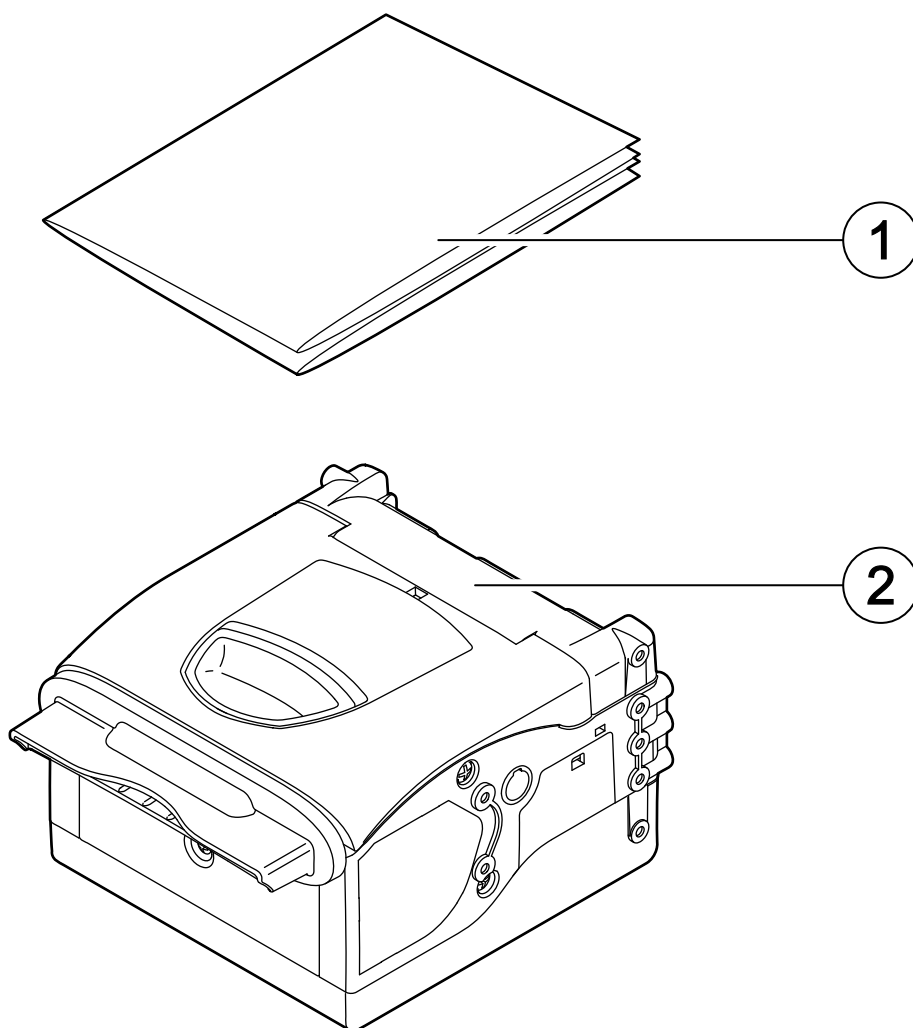



3.2 Device components: external views

VKP80III RX65 LAT

1. Device cover
2. Opening lever
3. Paper output
4. Right cursor for paper input
5. Paper input
6. Left cursor for paper input
7. FORM FEED key
8. LINE FEED key
9. Port for low paper sensor (external)
10. Expansion port (for optional external device)
11. Product label
12. Status LED
13. RS232 port
14. USB port
15. Power supply port

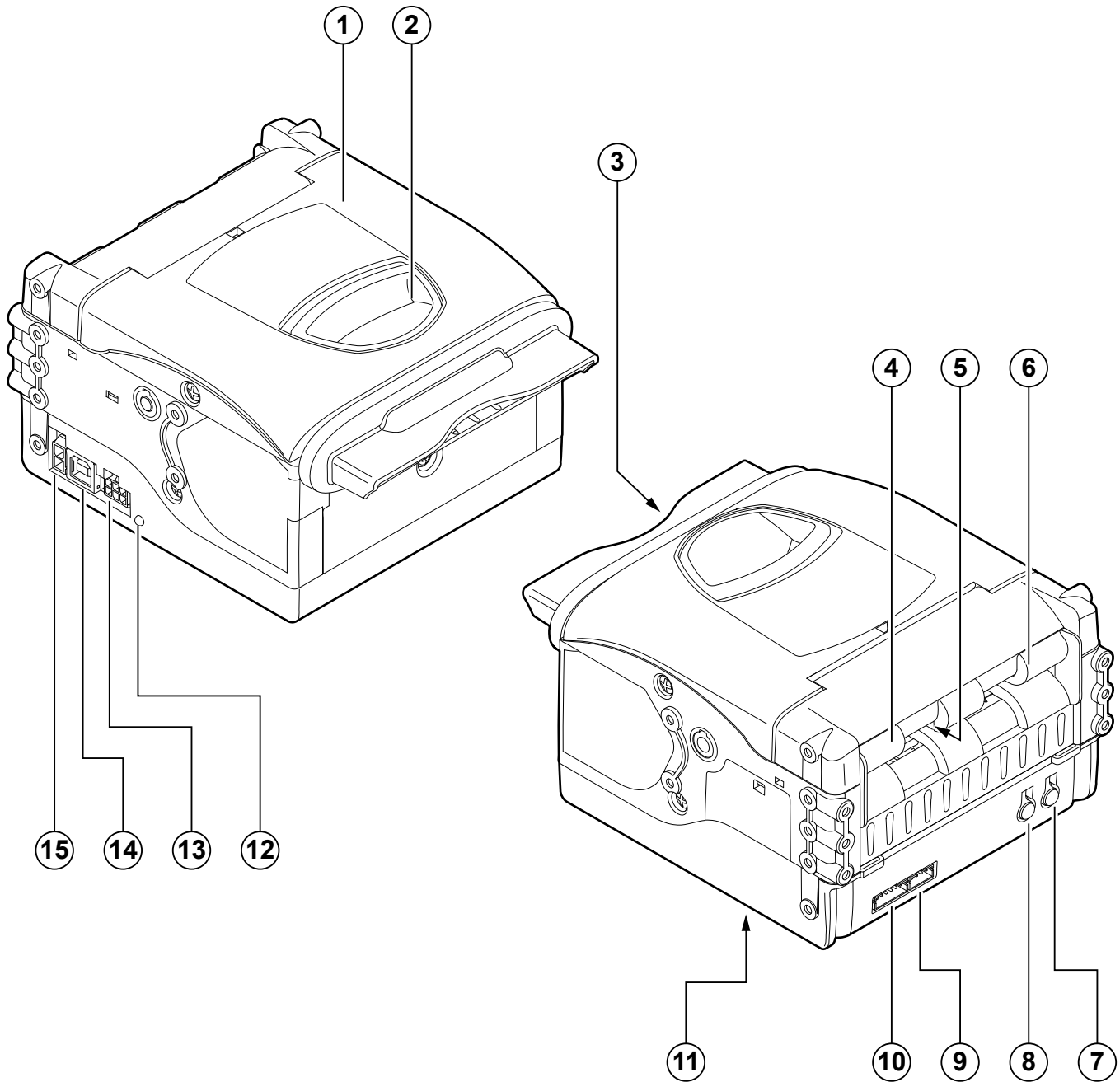



VKP80III RX65 REAR

1. Device cover
2. Opening lever
3. Paper output
4. Right cursor for paper input
5. Paper input
6. Left cursor for paper input
7. Status LED
8. FORM FEED key
9. LINE FEED key
10. Power supply port
11. USB interface port
12. RS232 interface port
13. Port for low paper sensor (external)
14. Expansion port (for optional external device)
15. Product label

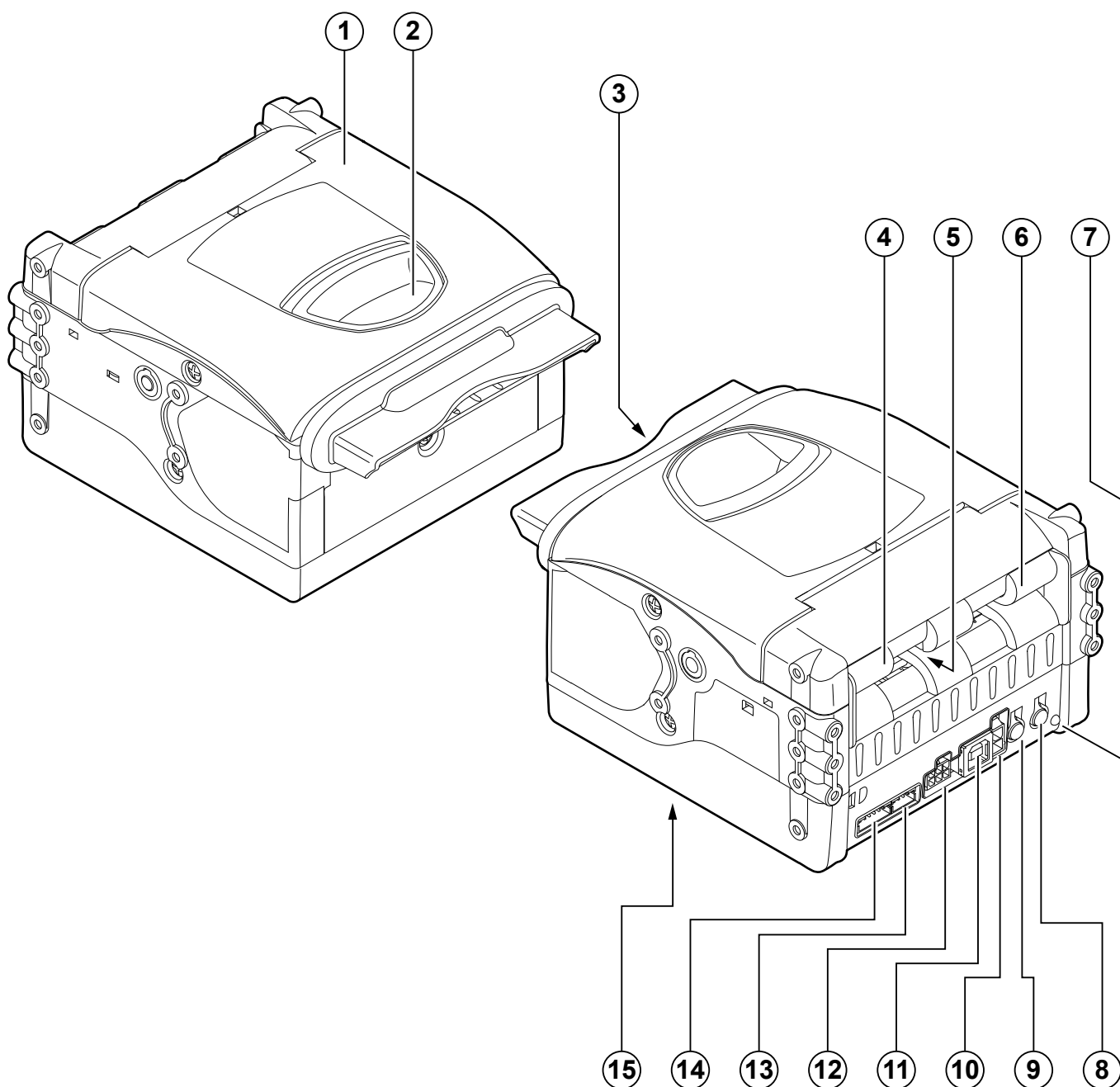



VKP80III ETH

1. Device cover
2. Opening lever
3. Paper output
4. Right cursor for paper input
5. Paper input
6. Left cursor for paper input
7. FORM FEED key
8. LINE FEED key
9. Port for low paper sensor (external)
10. Expansion port (for optional external device)
11. Product label
12. Status LED
13. Mini-USB port
14. Ethernet port
15. Power supply port

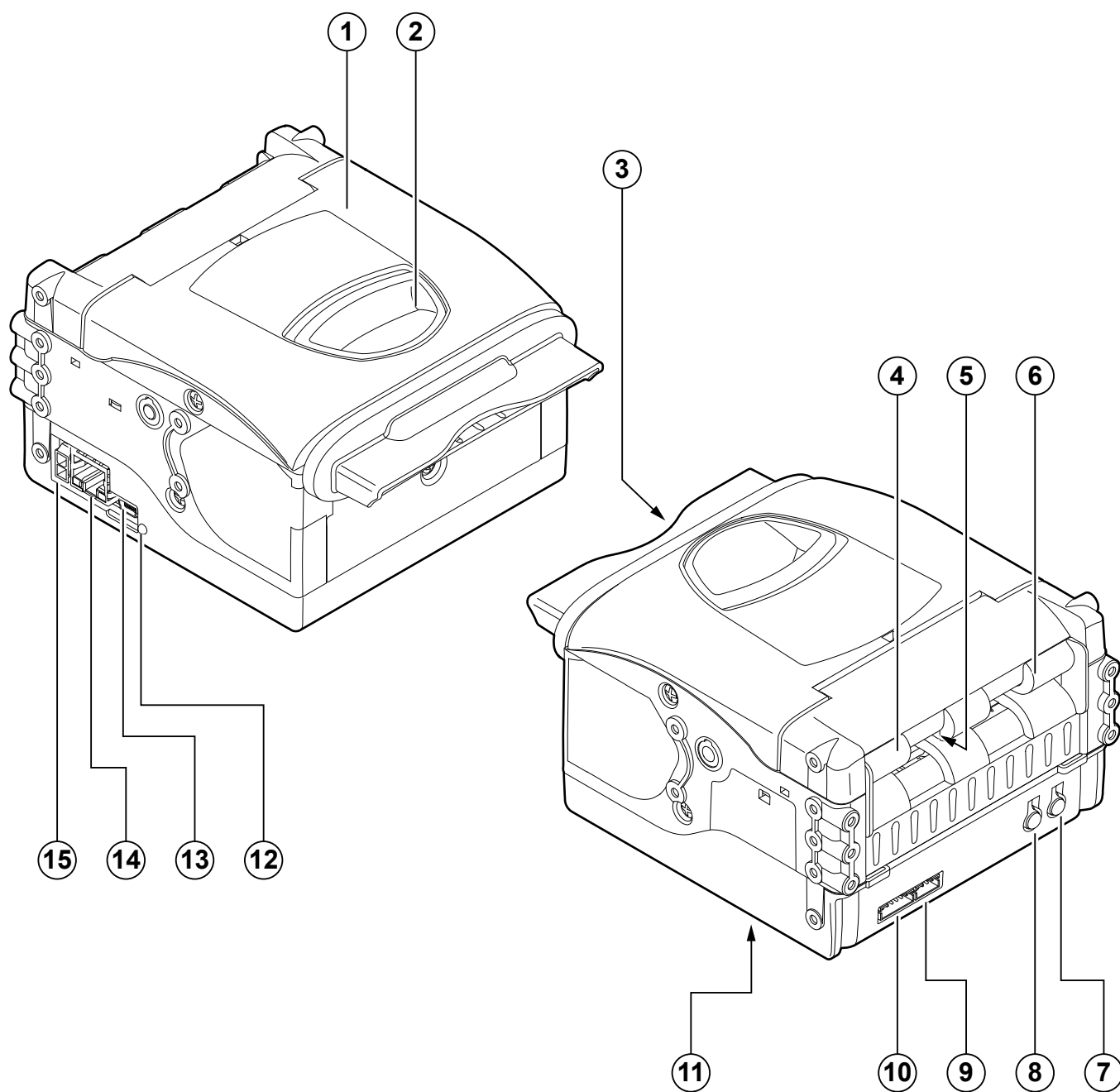

3.3 Device components: internal views

1. Ejector bulkhead
2. Upper left sensor for black mark (optional)
3. Printing head with sensor for paper in presence (built-in)
4. Paper out presence sensor
5. Upper right sensor for black mark (optional)
6. Lower mobile sensor for black mark
7. Autocutter

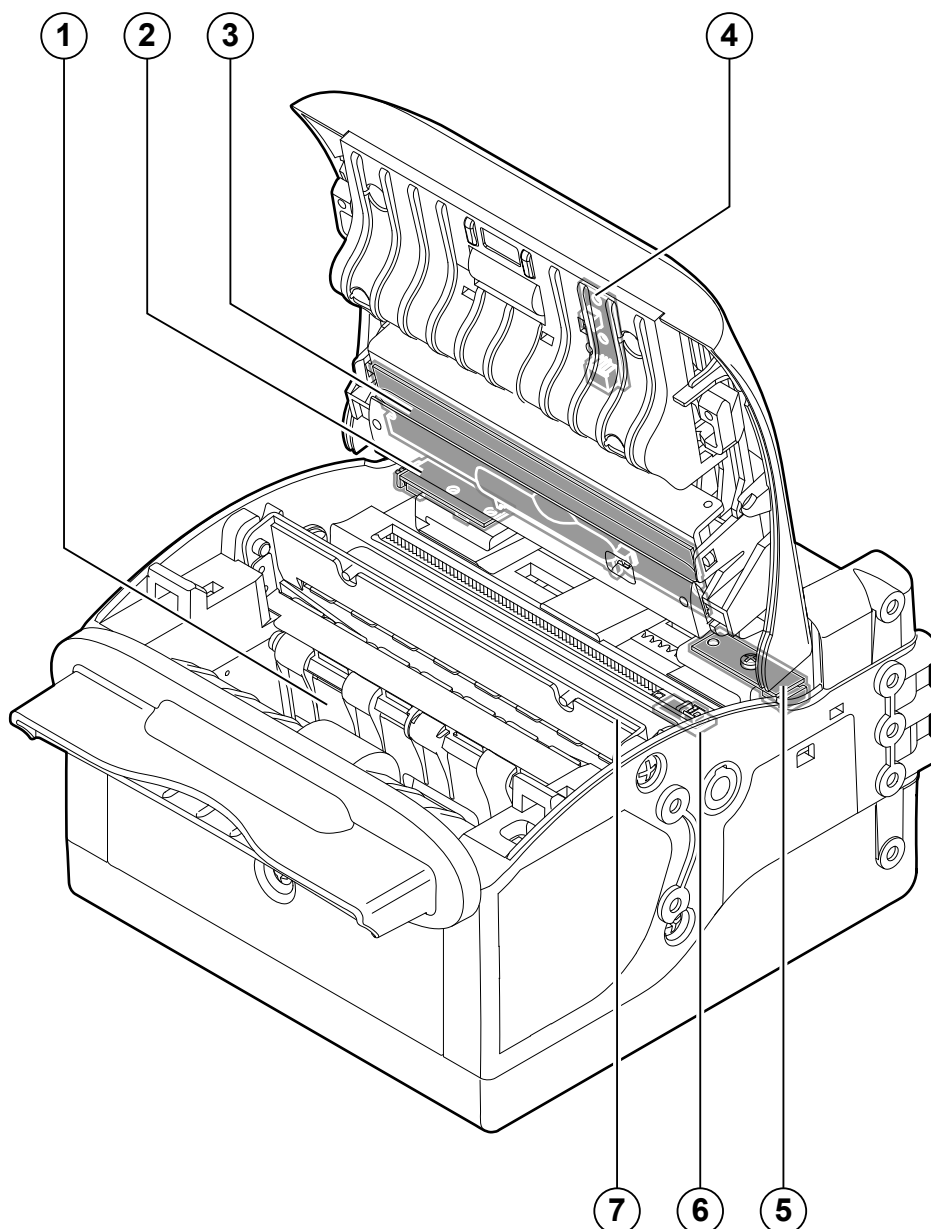

3.4 Device labels

The main data used to identify the machine are shown on the two labels attached to the bottom of the device or to the side of the device.

In particular, the product label shows the electrical data for the connection to a power source and the product code. The additional product label shows the serial number and the hardware revision (R).

product label

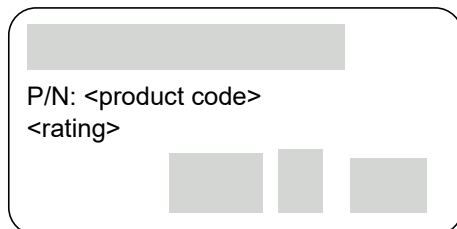

additional product label

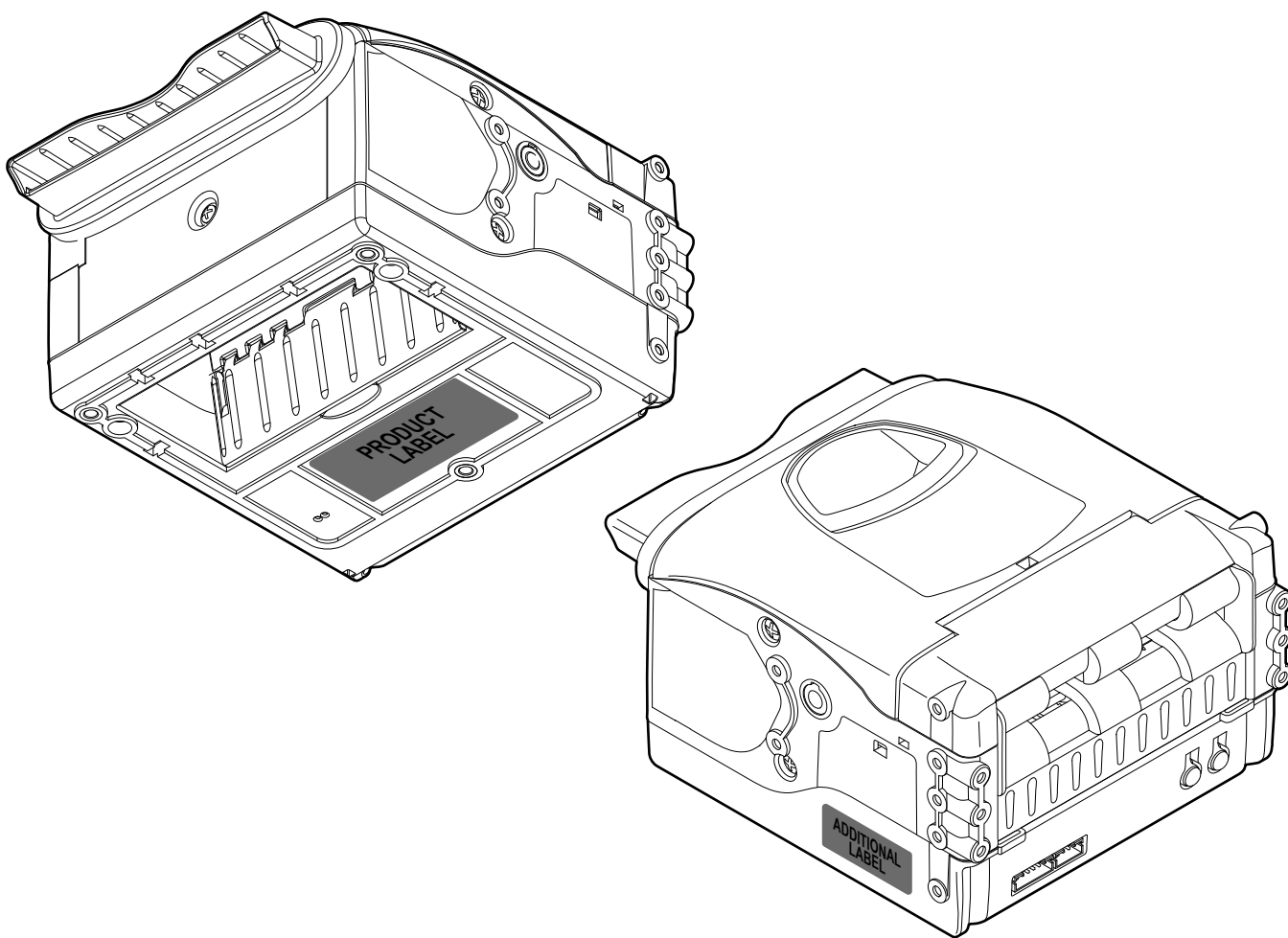
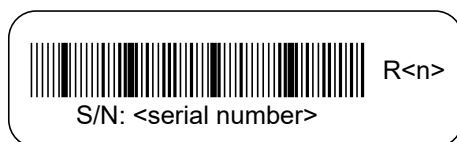

3.5 Key functions: power up

VKP80III RX65 LAT, VKP80III RX65 REAR

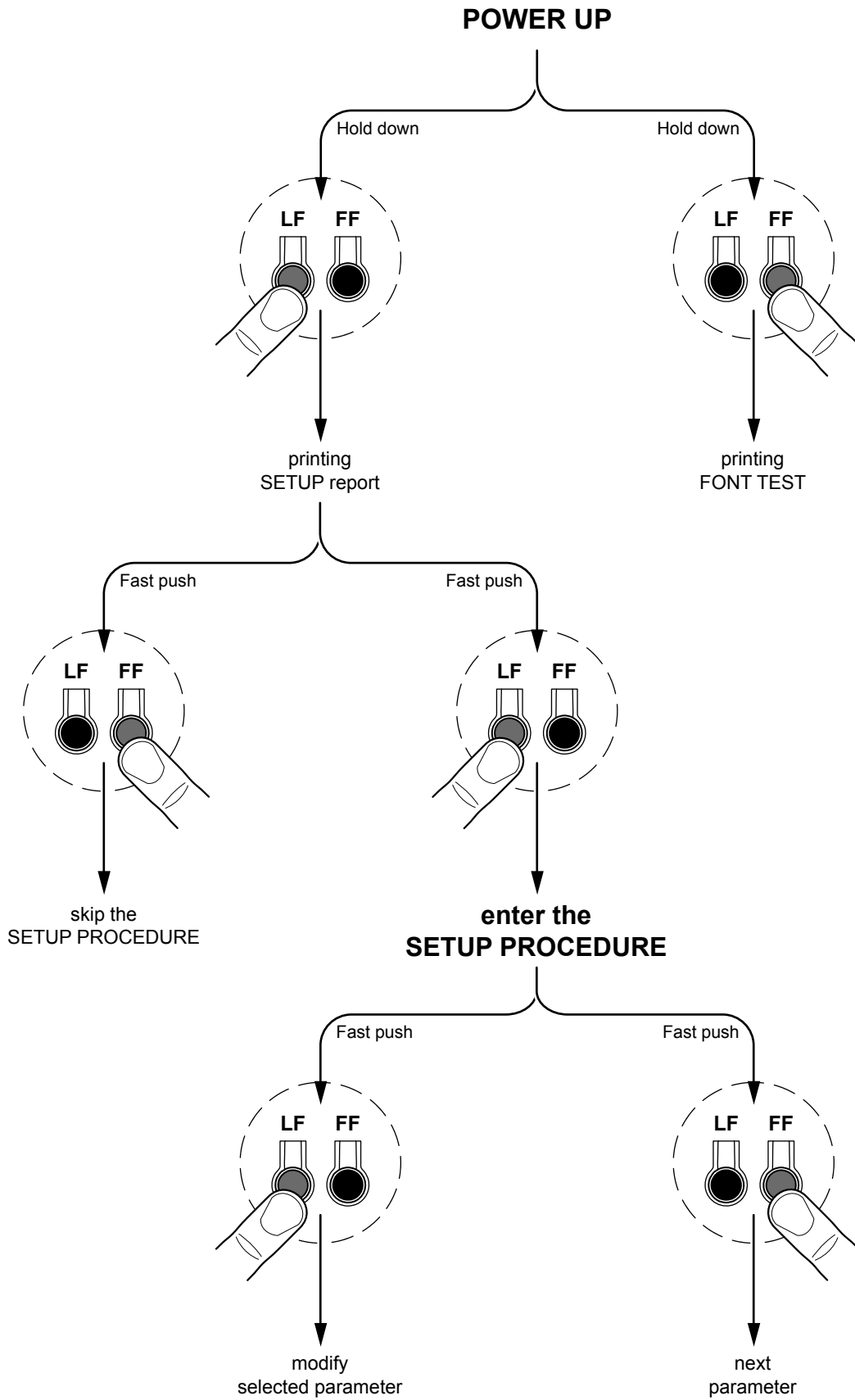

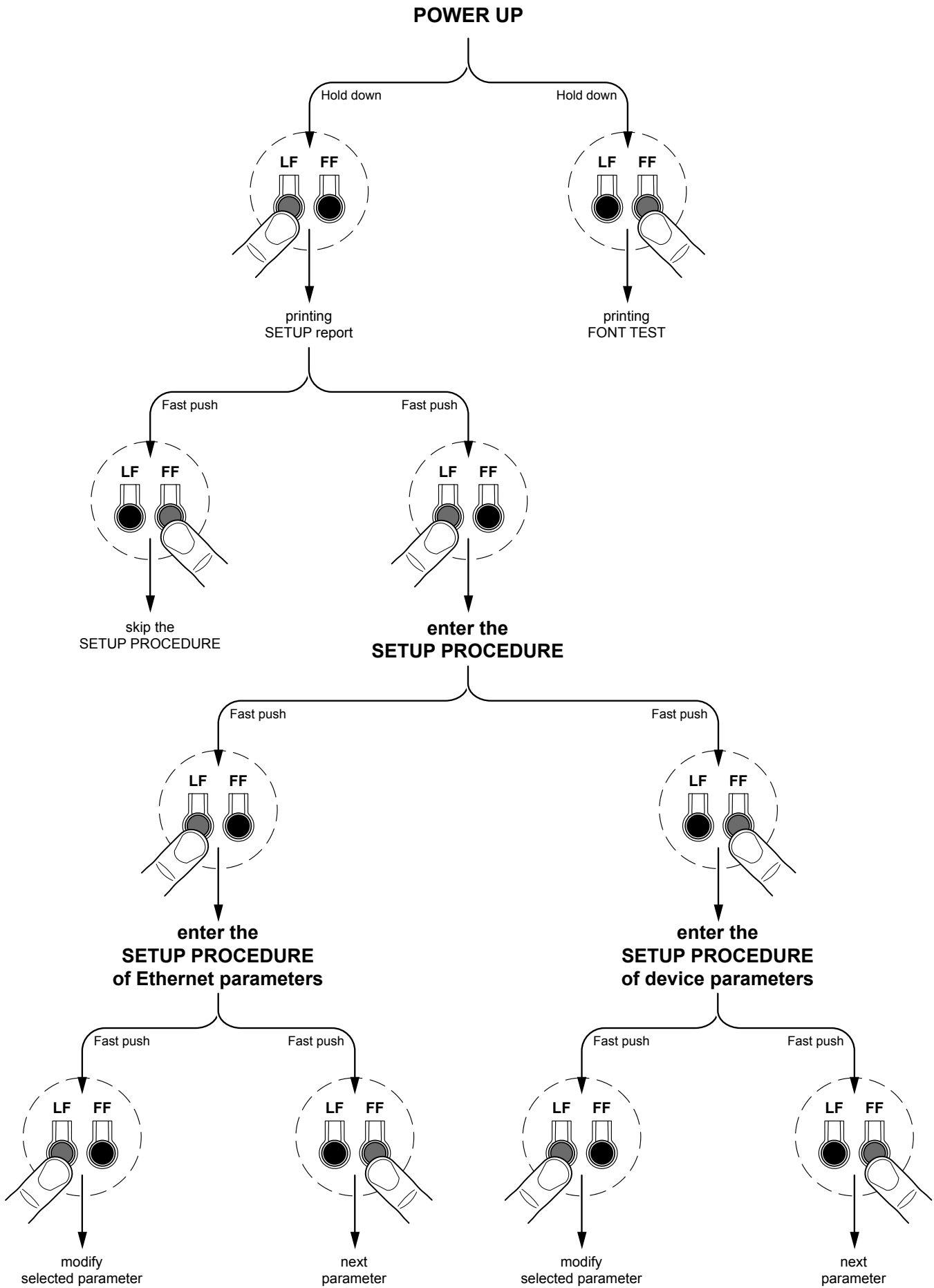

3.6 Key functions: standby

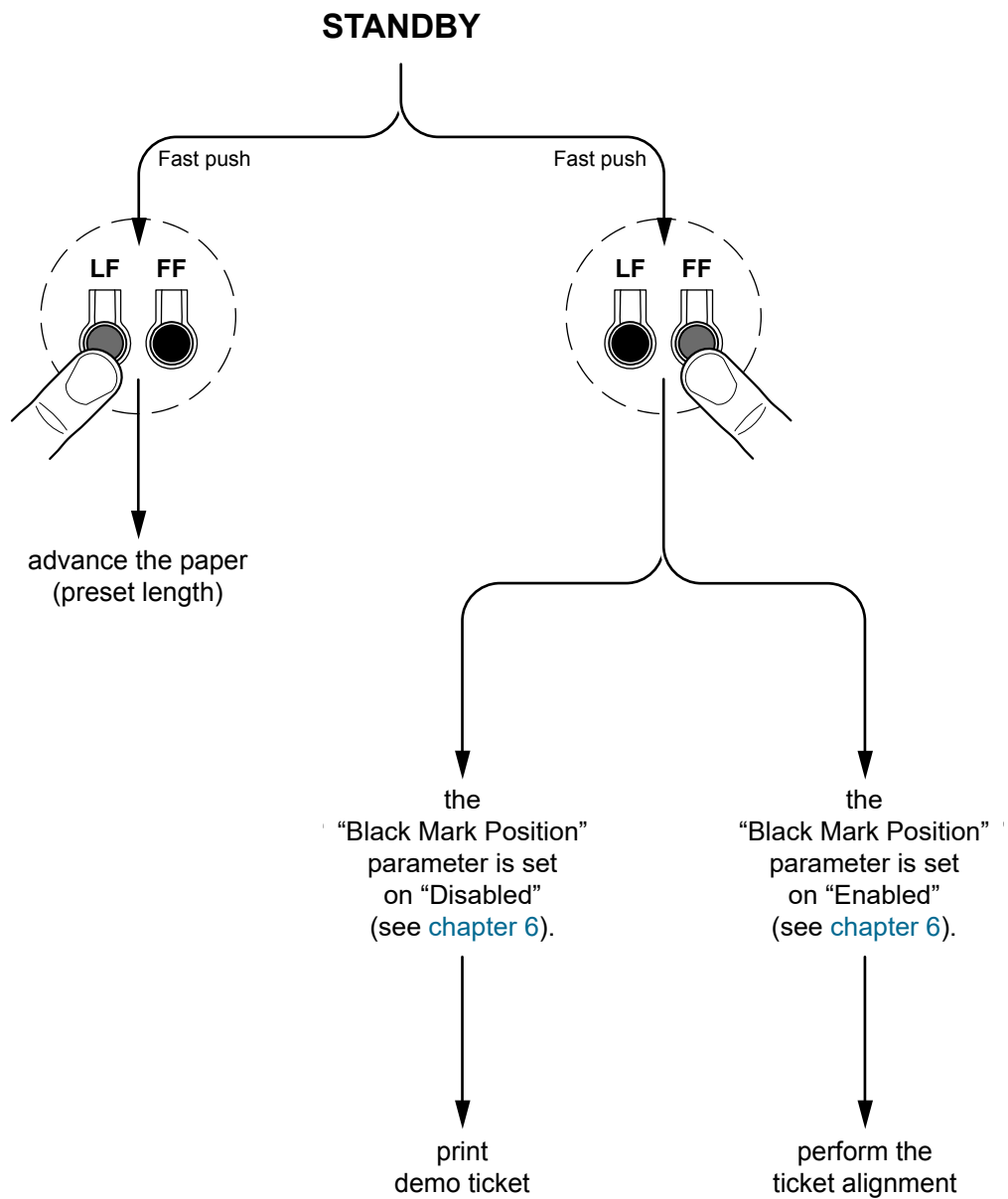



3.7 Status messages

The status LED indicates hardware status of device. Given in the table below are the various LED signals and the corresponding device status.

STATUS LED		DESCRIPTION
-	OFF	DEVICE OFF
GREEN	ON	DEVICE ON: NO ERROR
GREEN COMMUNICATION STATUS	x 1	RECEIVE DATA
	x 2	RECEPTION ERROR (PARITY, FRAME ERROR, OVERRUN ERROR)
	x 3	COMMAND NOT RECOGNIZED
	x 4	COMMAND RECEPTION TIME OUT
YELLOW RECOVERABLE ERROR	x 2	PRINTHEAD OVERHEATED
	x 3	PAPER END
	x 4	PAPER JAM
	x 5	POWER SUPPLY VOLTAGE INCORRECT
	x 6	COVER OPEN
RED UNRECOVERABLE ERROR	x 1	EJECTOR ROLLER ERROR
	x 2	EJECTOR BULKHEAD ERROR
	x 3	RAM ERROR
	x 4	EXTERNAL FLASH ERROR
	x 5	AUTOCUTTER ERROR

4 INSTALLATION

4.1 Fastening

ATTENTION: Correctly prepare the fixing holes for screws and the drilling for the paper mouth in order to avoid deformation and torsion of the device or its components which could compromise its operation.

The device is provided with three fixing holes on the bottom of device (see following figure). To fasten the device on a panel, use three M4 screws. All the dimensions shown in following figures are in millimetres.

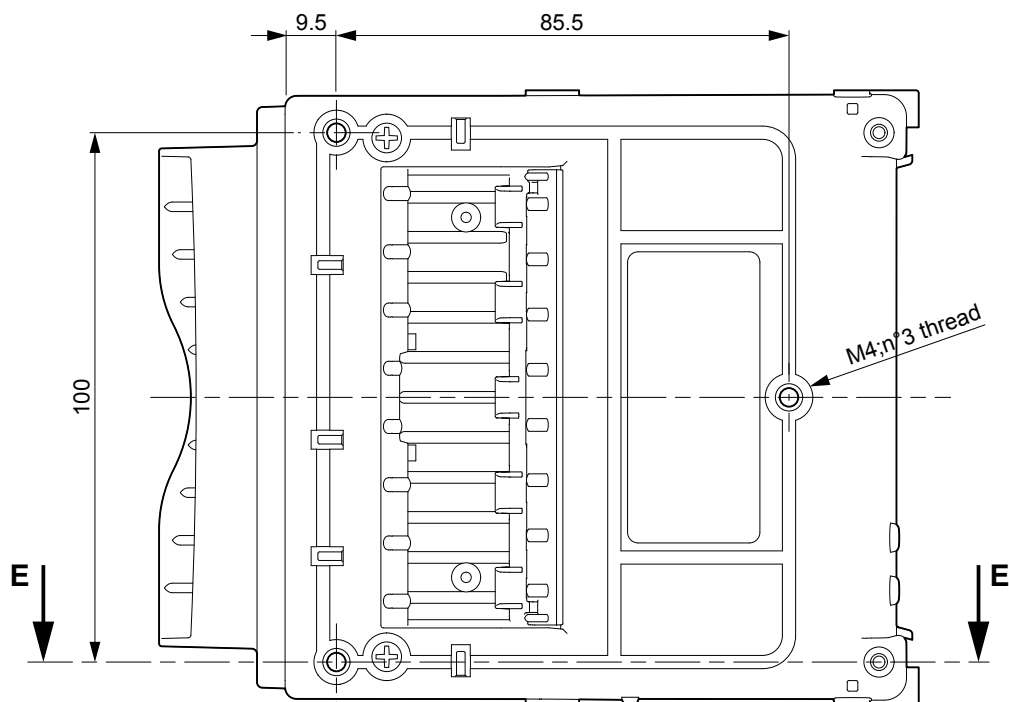

Furthermore, the panel must provide an opening for the paper handling that respects the measures shown below:

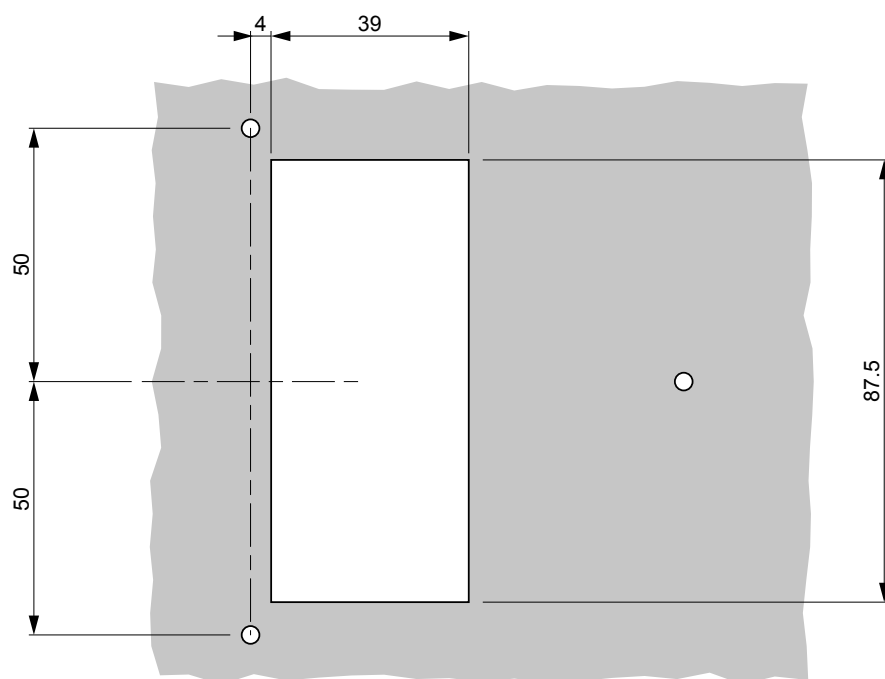



It's very important to consider the screws length not to damage the internal components placed near the fixing holes (see following figure).

Section E-E

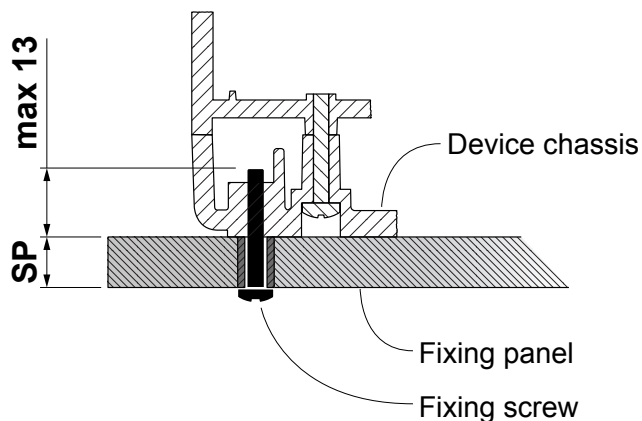

The screw length (L) will be calculated according to the thickness of the panel (Sp) on which the device is fixed, as follows:

$$L \leq 13 \text{ mm} + Sp$$

For example, if panel thickness is 10 mm (Sp = 10 mm), the maximum length for screws will be 23 mm.

When you place the device in the operating position, make sure to leave the proper free space around the device of at least 20 mm, also considering the space for opening the cover so to not compromise operation and maintenance. Refer to [paragraph 9.4](#) for models dimensions.

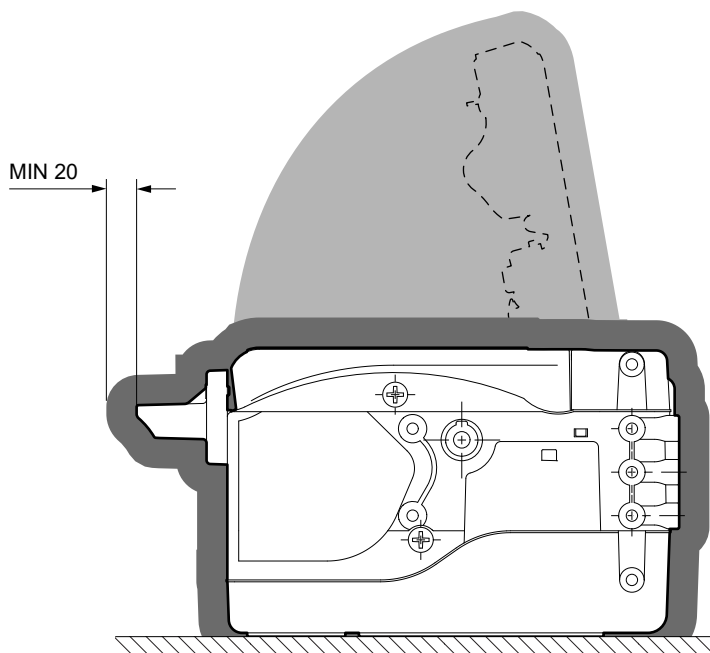



4.2 Connections

The following figures show the possible connections for the device.

VKP80III RX65 LAT

When the RS232 and USB communication cables are connected to the device at the same time, communication takes place via the USB port.

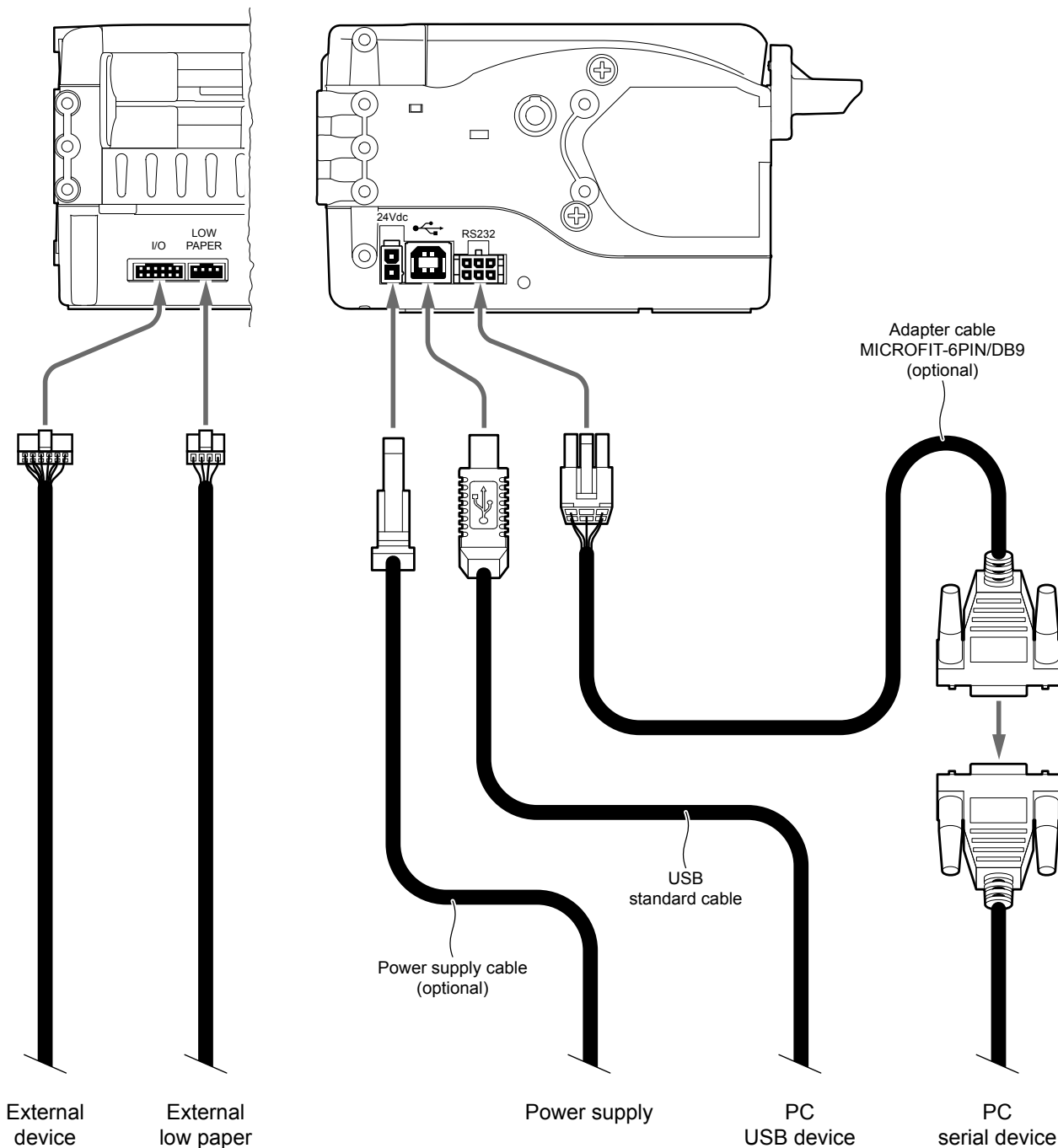

ATTENTION:

It is recommended to secure with a tie the adapter cable MICROFIT-6PIN/DB9 to a fixed support in order to prevent the connector on control board bears the weight of the cables.

In some using conditions, we recommend the installation of a ferrite core on the power supply cable.



VKP80III RX65 REAR

When the RS232 and USB communication cables are connected to the device at the same time, communication takes place via the USB port.

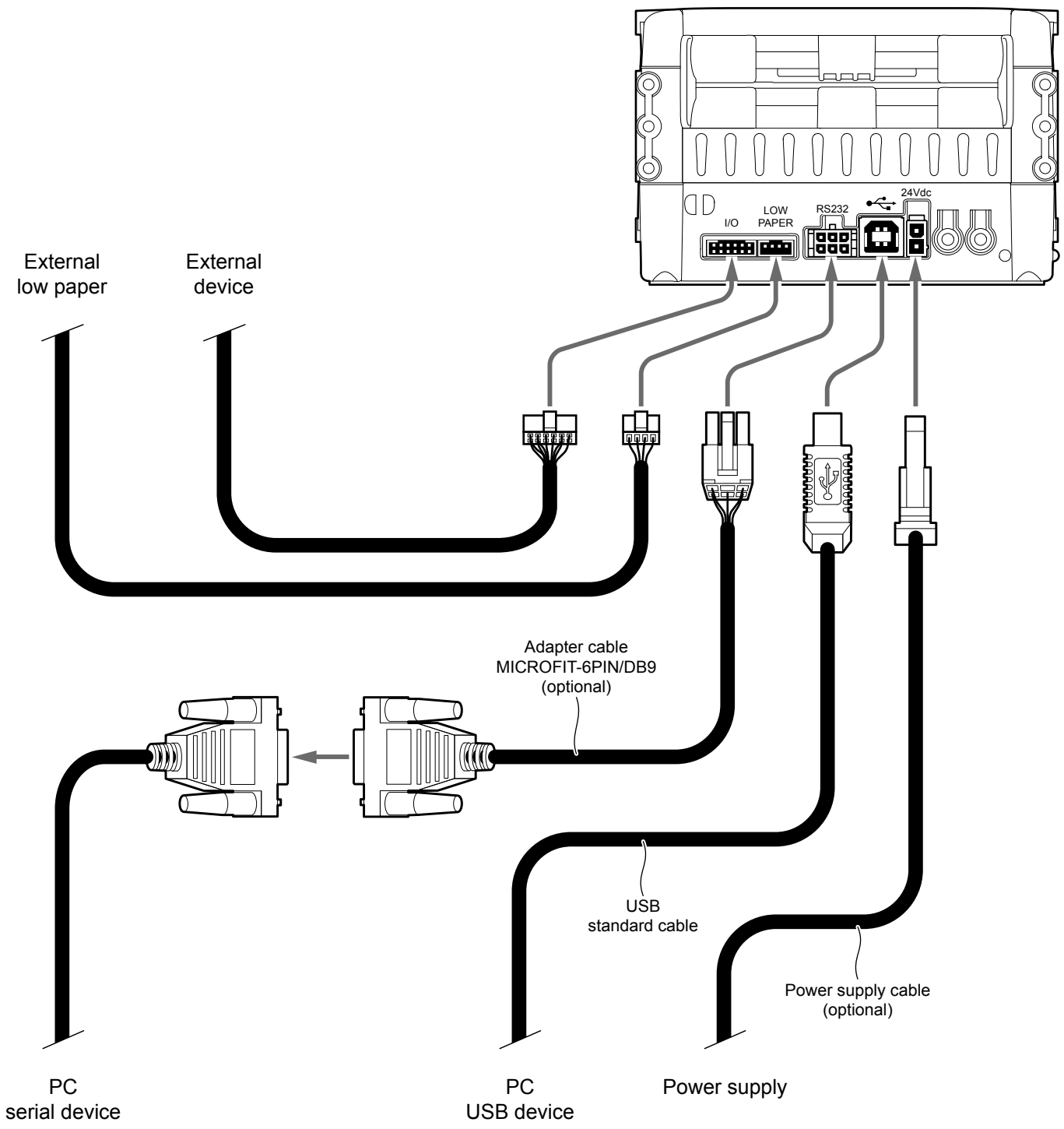

ATTENTION:
 It is recommended to secure with a tie the adapter cable MICROFIT-6PIN/DB9 to a fixed support in order to prevent the connector on control board bears the weight of the cables.

In some using conditions, we recommend the installation of a ferrite core on the power supply cable.



VKP80III ETH

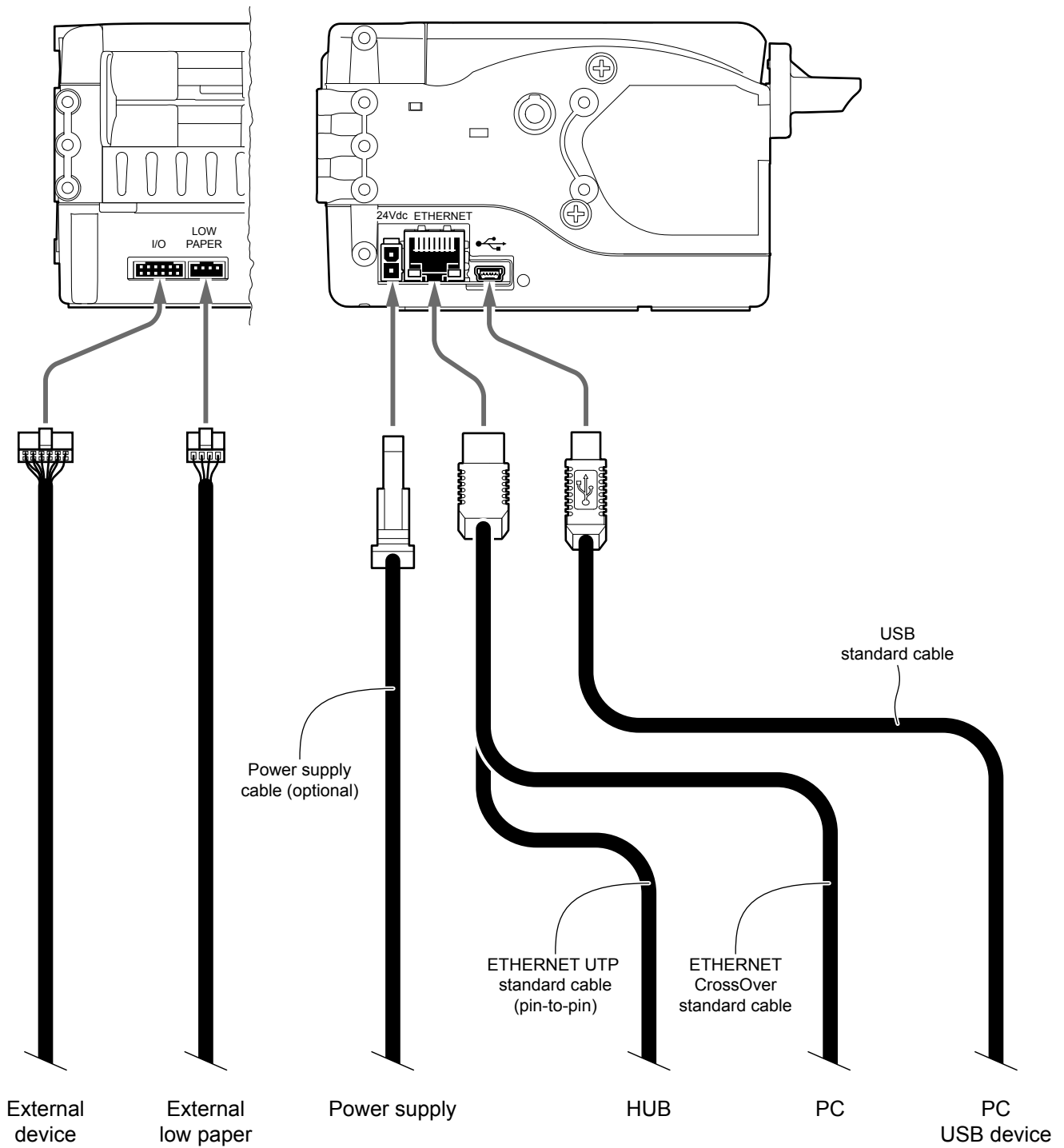

ATTENTION:

In some using conditions, we recommend the installation of a ferrite core on the power supply cable.

4.3 Pinout

VKP80III RX65 LAT, VKP80III RX65 REAR



POWER SUPPLY

Male Molex connector series 5569 vertical (n° 39-30-1020)

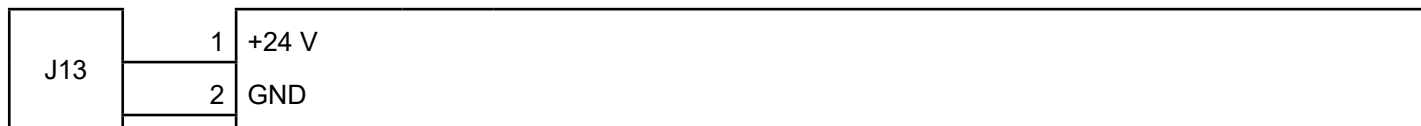

The following figure shows the connector pinout of the power supply cable for the device:

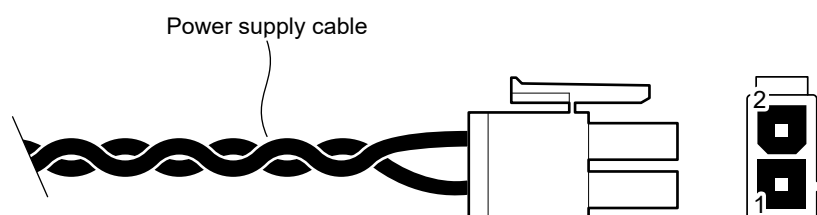

Female Molex connector series 5557 (n.39-01-3022)

PIN	Cable color	Signal
1	Red	+24V
2	Black	GND

ATTENTION:

Respect power supply polarity.

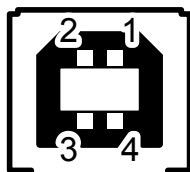

USB INTERFACE

Female USB type B connector



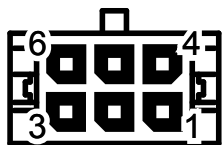

SERIAL INTERFACE

Female MICROFIT-6PIN connector (cable insertion side)

J1	1	DT	(out)	When +VRS232, device is ready
	2	RX	(in)	During reception, takes the value -VRS232 and +VRS232, depending on data
	3	GND		
	4	TX	(out)	During transmission, takes the value -VRS232 and +VRS232, depending on data
	5	RT	(out)	When +VRS232, device is ready to receive data
	6	+24VM		

DEVICE > PC connection

Use the adapter cable MICROFIT-6PIN/DB9 and a RS232 serial cable to connect the printer to a personal computer. The following picture shows an example of connection between the device and a personal computer using a 9 pin serial connector.

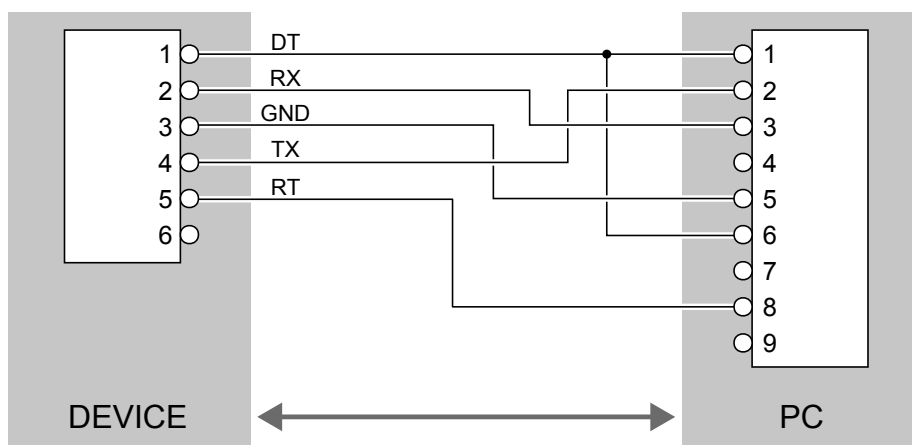

When use a serial cable, we recommend the installation of a ferrite core on the power supply cable.

Given the presence of the RS232 standard, logic value "0" corresponds to the voltage value +VRS232 (voltage value between +3Vdc and +15Vdc) and logic value "1" corresponds to the voltage value -VRS232 (voltage value between -3Vdc and -15Vdc).

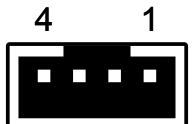

EXTERNAL LOW PAPER

Male JST-4pin connector series PH 90° (S4B-PH-K-S)

J5	1	+3.3VO		
	2	NPE	(in)	When > 3 V the paper is low
	3	GND		
	4	VLED-SENS	(out)	Signal to turn on/off the infreared sensor LED

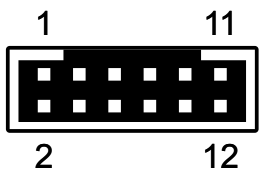

EXTERNAL DEVICE

Male JST-12pin connector series PHD 90° (S12B-PHDSS-B)

J17	1	SW-FF	(out)	When 0V the key is pressed
	2	GND		
	3	SW-LF	(out)	When 0V the key is pressed
	4	MR	(in)	Printer reset (0V)
	5	EX-LEDR	(out)	When 0V turns on the red LED
	6	RXD0/SCL1	(in/out)	Auxiliary serial reception/ i2c clock
	7	EX-LEDV	(out)	When 0V turns on the green LED
	8	TXD0/SDA1	(in/out)	Auxiliary serial transmission/ i2c data
	9	MOT-AUX+	(out)	Auxiliary motor
	10	+3.3VO		
	11	MOT-AUX-	(out)	Auxiliary motor
	12	+24VM		

VKP80III ETH



POWER SUPPLY

Male Molex connector series 5569 vertical (n° 39-30-1020)

J13	1	+24 Vdc
	2	GND

The following figure shows the connector pinout of the power supply cable for the device:

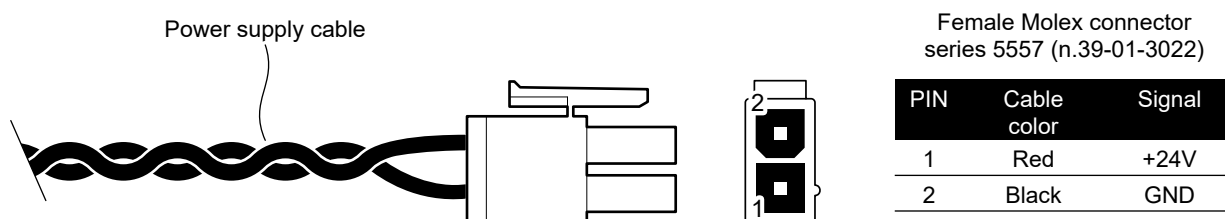

ATTENTION:
Respect power supply polarity.



MINI-USB INTERFACE

Female Mini-USB type B connector

J2	1	USB0_VBUS (in)
	2	USB0_D- (in/out)
	3	USB0_D+ (in/out)
	4	n.c.
	5	GND

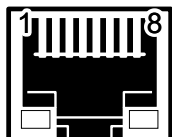

ETHERNET INTERFACE

Female RJ45 connector

J23	1	RX +1
	2	+3.3V
	3	RX -1
	4	TX +1
	5	+3.3V
	6	TX -1
	7	n.c
	8	GND
	9	+3.3 V
	10	LED-LNK
	11	+3.3 V
	12	LED-LAN
	13	SH1
	14	SH2

The functionality of two LEDs are specified in following tables:

- For 10Base-T connection:

LED	FUNCTION
LED-LNK	Link (yellow color): the LED lights up when a connection is active.
LED-LAN	Rx/Tx: (green color): the LED lights up when occurs a data reception or transmission.

- For 10/100Base-TX connection:

LED	FUNCTION
LED-LNK	The LED light (yellow color) on when a connection is active and flashes when occurs a data reception or transmission.
LED-LAN	The LED light (green color) on when occurs a 100 Mbit connection and off when occurs a 10 Mbit connection.

The device automatically recognizes the type of connection (cross or pin-to-pin).

The pinout shown in table represents the input signals to component J23 before the isolation voltage transformer (through-hole pin).

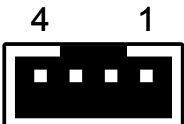

EXTERNAL LOW PAPER

Male JST-4pin connector series PH 90° (S4B-PH-K-S)

J5	1	+3.3VO		
	2	NPE	(in)	When >3 V the paper is low
	3	GND		
	4	VLED-SENS	(out)	Signal to turn on/off the infreared sensor LED

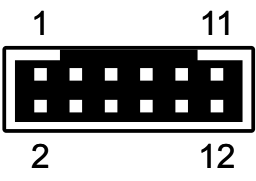

EXTERNAL DEVICE

Male JST-12pin connector series PHD 90° (S12B-PHDSS-B)

J17	1	SW-FF	(out)	When 0V the key is pressed
	2	GND		
	3	SW-LF	(out)	When 0V the key is pressed
	4	MR	(in)	Printer reset (0V)
	5	EX-LEDR	(out)	When 0V turns on the red LED
	6	RXD0/SCL1	(in/out)	Auxiliary serial reception/ i2c clock
	7	EX-LEDV	(out)	When 0V turns on the green LED
	8	TXD0/SDA1	(in/out)	Auxiliary serial transmission/ i2c data
	9	MOT-AUX+	(out)	Auxiliary motor
	10	+3.3VO		
	11	MOT-AUX-	(out)	Auxiliary motor
	12	+24VM		



4.4 Driver and SDK

In the website www.custom4u.it are available the drivers for the following operating system:

OPERATING SYSTEM	DESCRIPTION	INSTALLATION PROCEDURE
Windows	Driver for Windows 7 (32/64 bit)	From the Start menu, press Run and type-in the path where the SW was saved on your PC, then click OK. Follow the instructions that appear on the screen to install the driver.
	Driver for Windows 10 (32/64 bit)	
	Driver for Windows 11 (64 bit)	
	Self-installing driver for VIRTUAL COM (32/64 bit) (see paragraph 6.6)	
	OPOS SDK	
	JavaPOS SDK	
Windows API SDK		
Linux	Driver CUPS (32/64 bit)	Follow the instruction get back on the "Readme.txt" file. You can find it in the software package downloaded in advance.
	Driver for VIRTUAL COM (32/64 bit) (see paragraph 6.6)	
Android	JavaPOS SDK	Extract the zipped folder to the destination path desired. Follow the instructions present in the software package that you downloaded on how to install and use the SDK.
	ANDROID API SDK	
iOS ⁽¹⁾	iOS API SDK	Extract the zipped folder to the destination path desired. Follow the instructions present in the software package that you downloaded on how to install and use the SDK.

NOTE:
(1) : Only for VKP80III ETH.

5 OPERATION

5.1 Cover opening

To open the device cover proceed as follows:

1

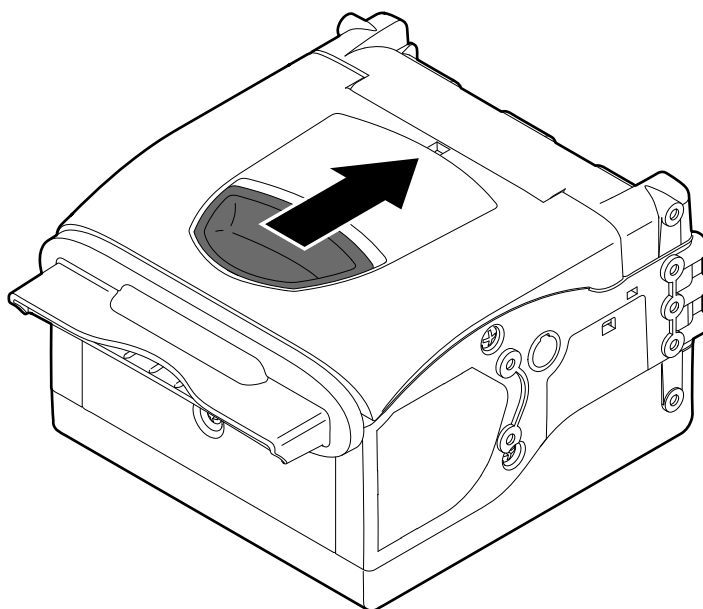

Unhook the device cover by using the opening lever.

2

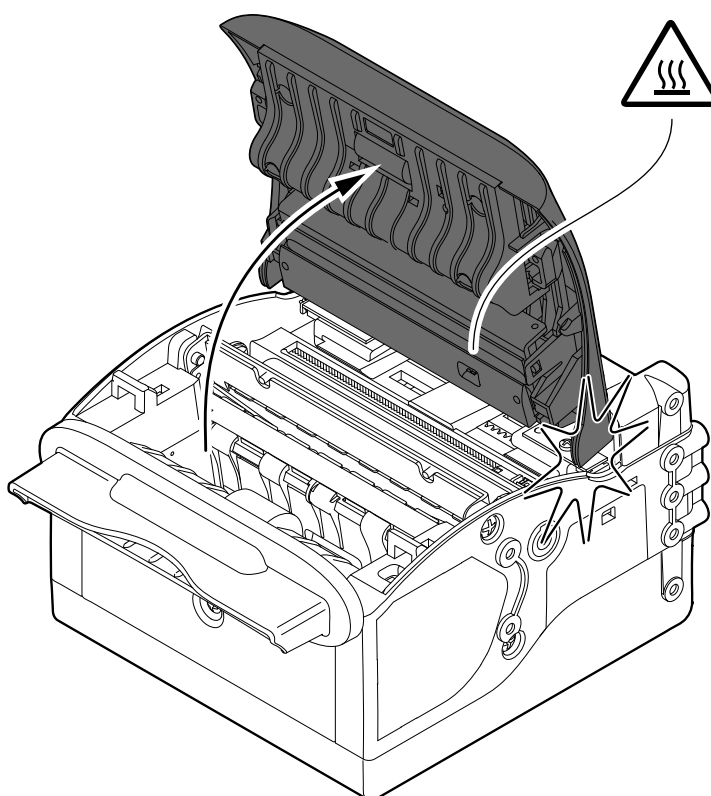

Open the device cover to the lock position.

5.2 Adjusting paper width

Paper width may be adjusted from 50 mm to 82.5 mm by moving the adjustable cursors left and right located on the paper infeed.

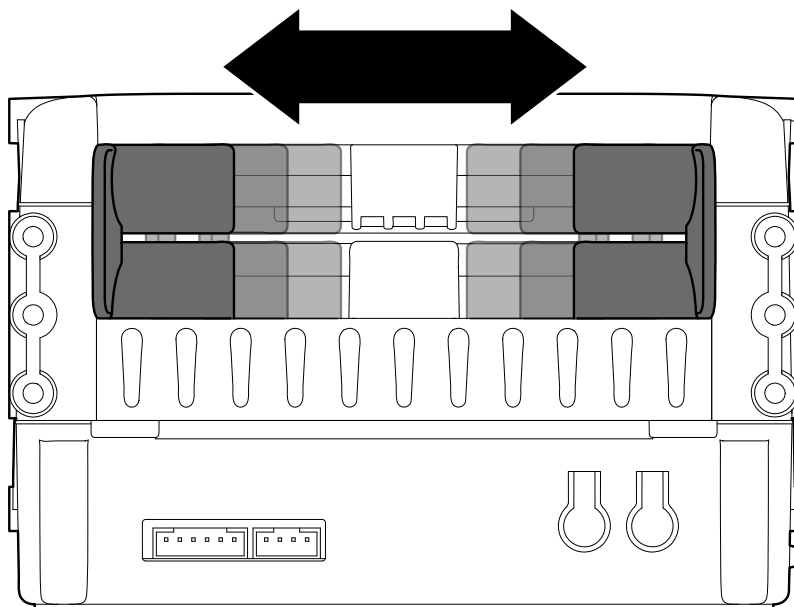

5.3 Adjusting paper width with the paper roll holder (optional)

The two accessories available for the device (code 974DX010000001 and code 974DX010000005) allow the use of paper roll width from 60 mm to 82.5 mm.

To adjust the width of the paper roll case, rotate the knob as shown in the following figure.

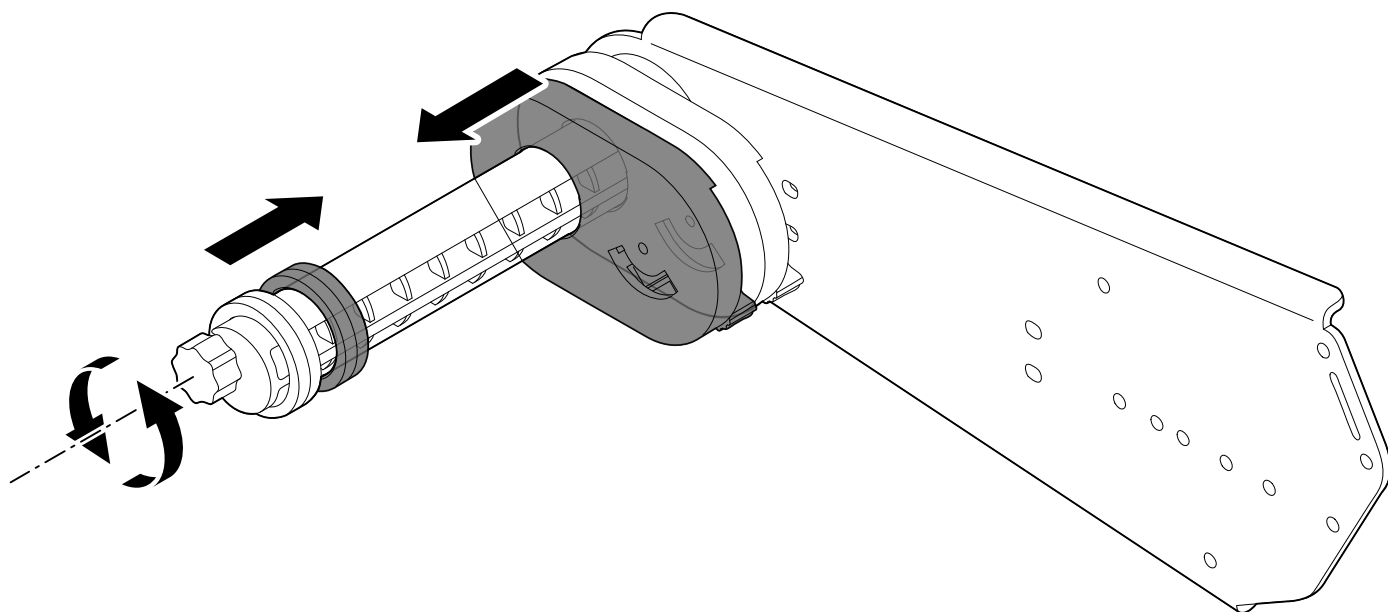

5.4 Adjusting the paper stock with the paper roll holder (optional)

The two accessories available for the device (code 974DX010000001 and code 974DX010000005) allow to change the position of the low paper sensor to adjust the amount of paper on the roll under which report the low paper.

Use the lever shown in figure to move the low paper sensor: move the lever up to increase the paper stock, move the lever down to decrease the paper stock.

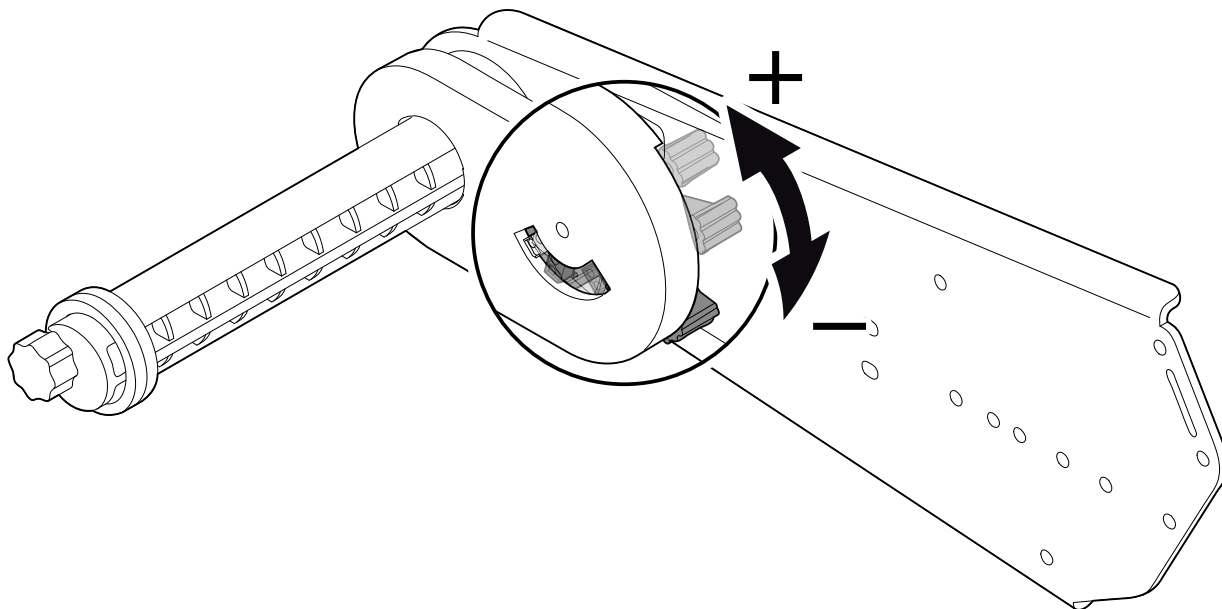



5.5 Low paper sensor

The device provides as an accessory (see [chapter 11](#)) a low paper sensor with the cable (see following figure). To fix the sensor, use an M3 screw not supplied.

All the dimensions shown in following figures are in millimetres.

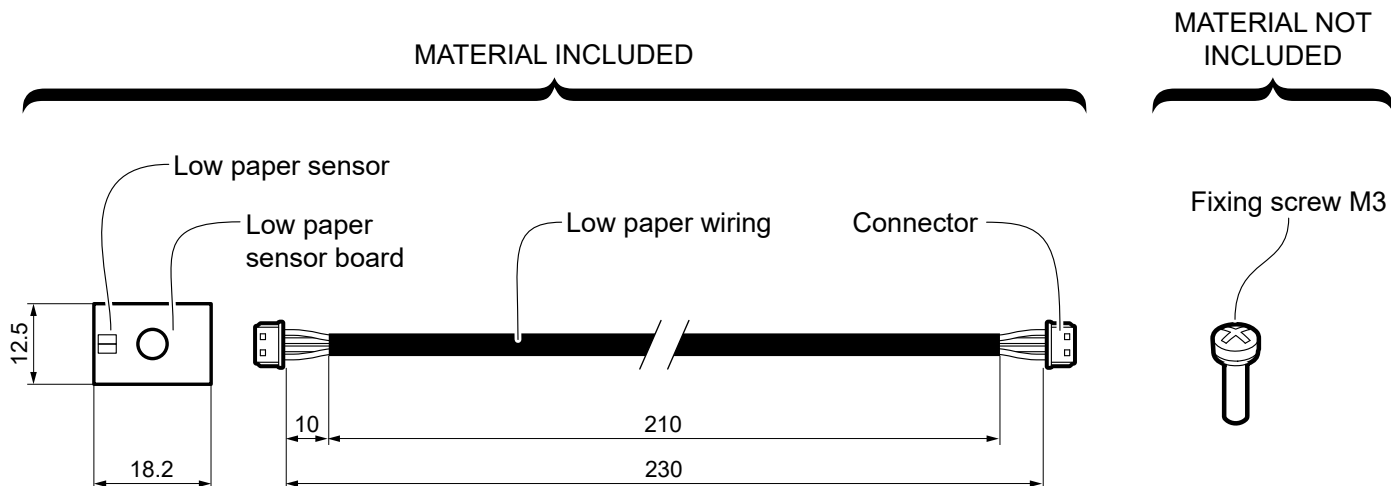

For the assembly procedure, proceed as follows:

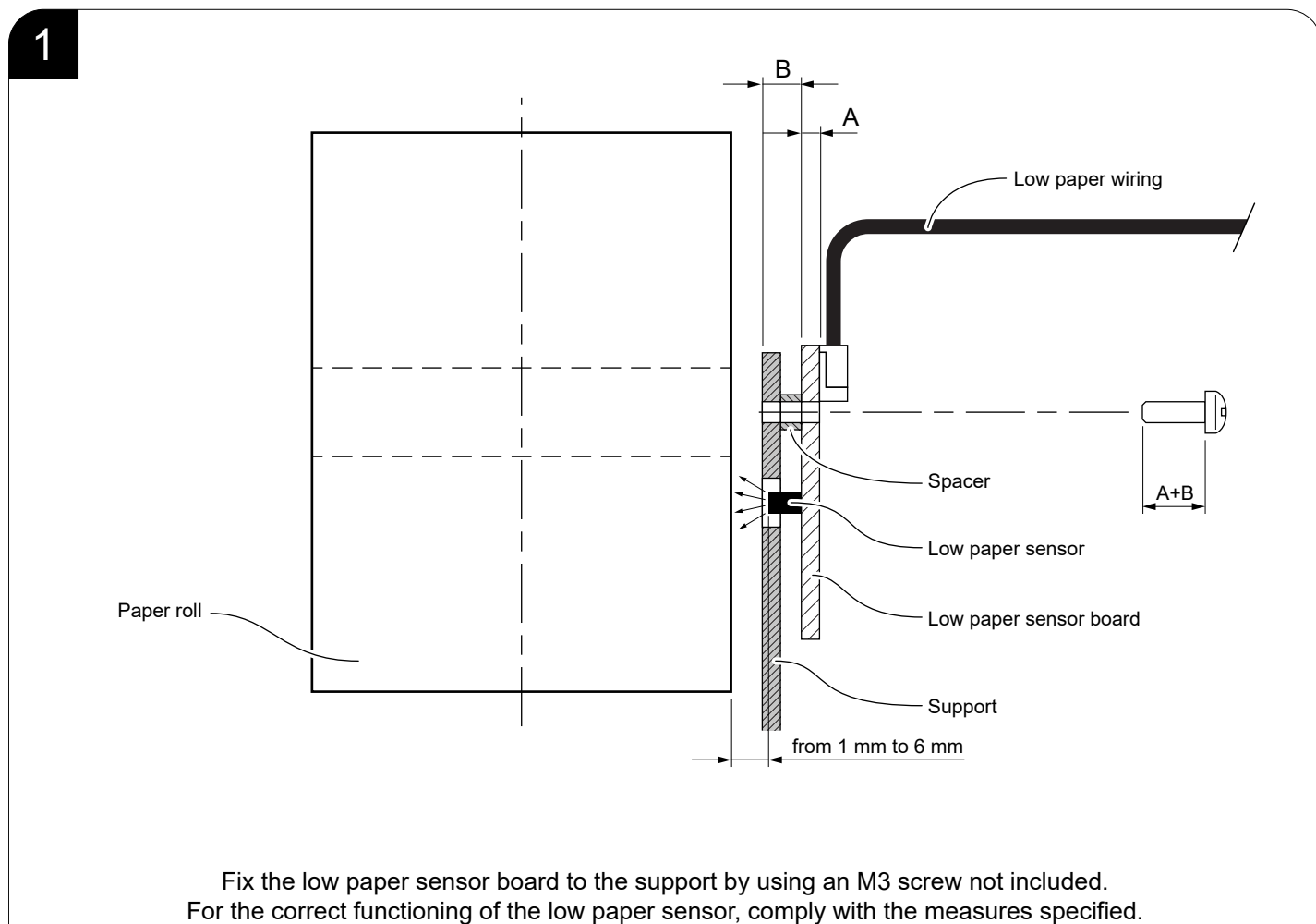

2

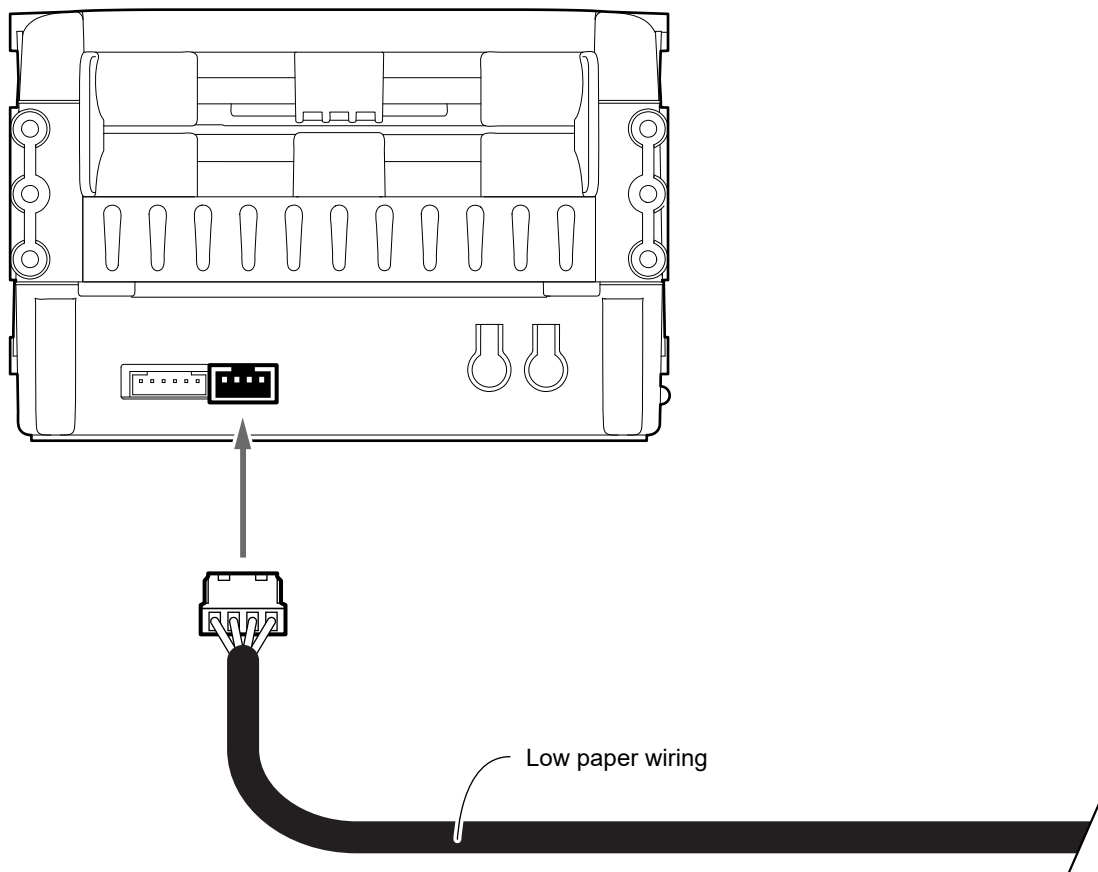

Connect the wiring coming from the low paper sensor board at the connector shown in figure.

5.6 Adjusting the alignment sensors

The device is equipped with a mobile sensor for the detection of the alignment black mark placed on the non-thermal side of paper (located lower than the plane of the paper inside the device).

The device user will need to manually move these mobile sensor according to the position of the black mark on the paper (see next paragraphs).

To use this sensor, you must set the “Black Mark Position” setup parameter on the “Bottom” value (see [paragraph 6.8](#)).

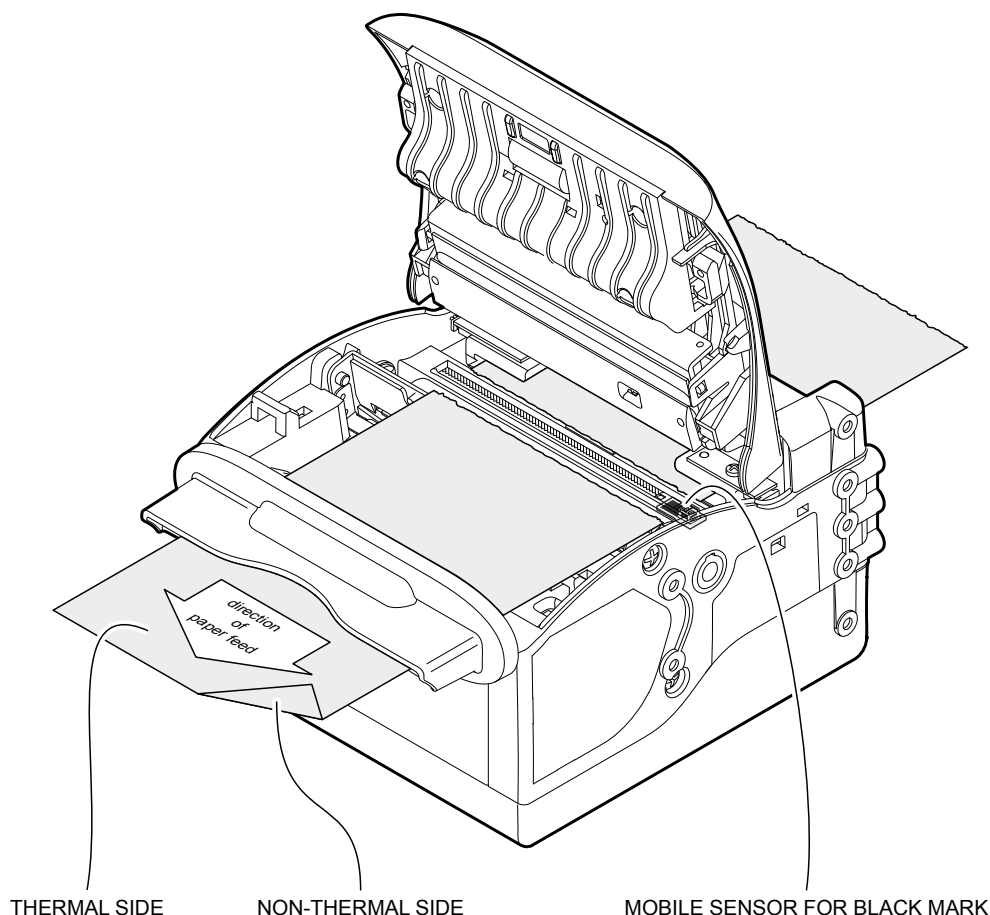

In addition, the printer can be optionally equipped with a sensor for alignment black mark placed on the thermal side of paper (located upper than the plane of the paper inside the printer).

This optional sensor can be placed on the left cursor or on the right cursor of the paper infeed. The sensor position is adjusted by moving the paper infeed cursors during the paper width adjusting.

To use this sensor for black mark detection, you must set the “Black Mark Position” setup parameter on the “Top Side” value (see [paragraph 6.8](#)).

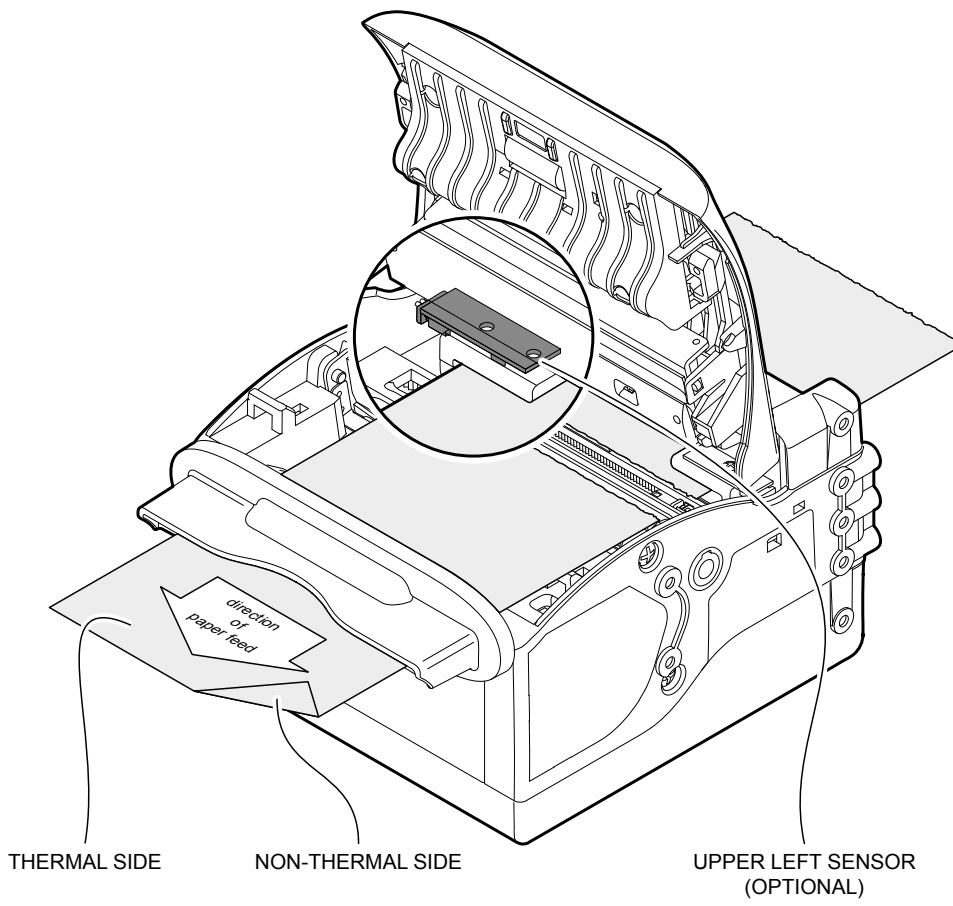
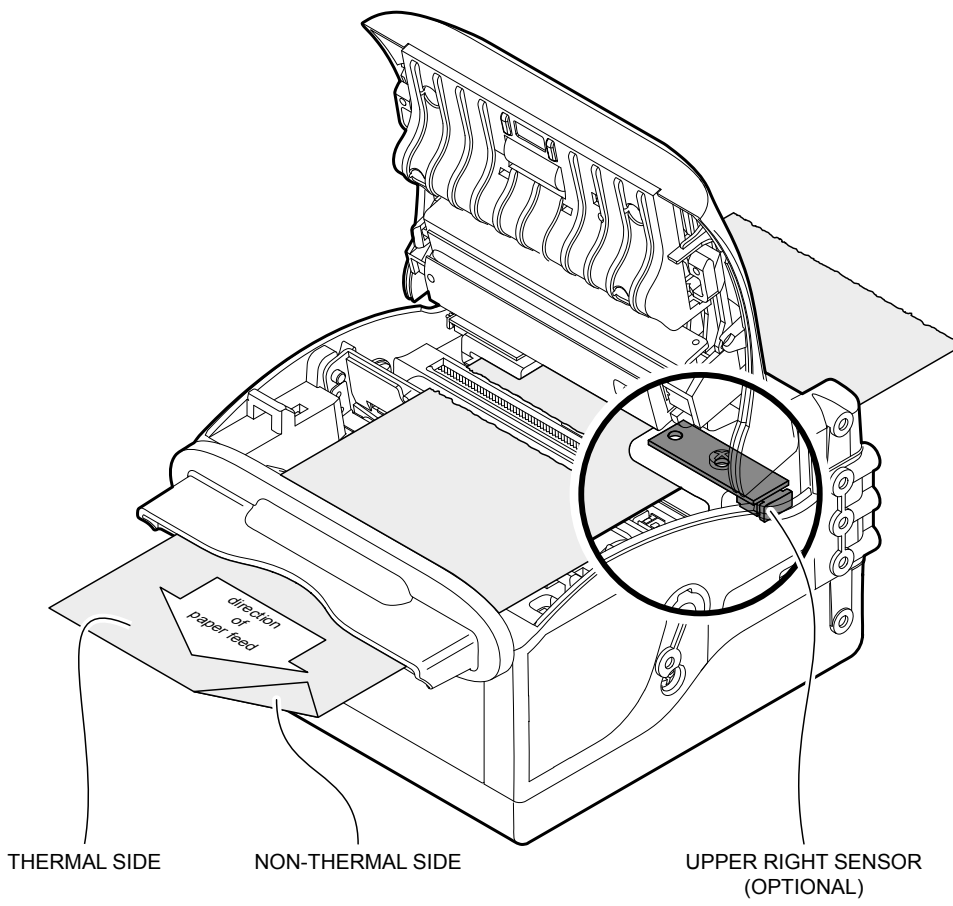



To adjust the mobile sensor position according to the black mark position on paper, first adjust the paper width (see [paragraph 5.2](#)), then open the device cover (see [paragraph 5.1](#)) and move the sensor to the desired using a small screwdriver or a pointed object.

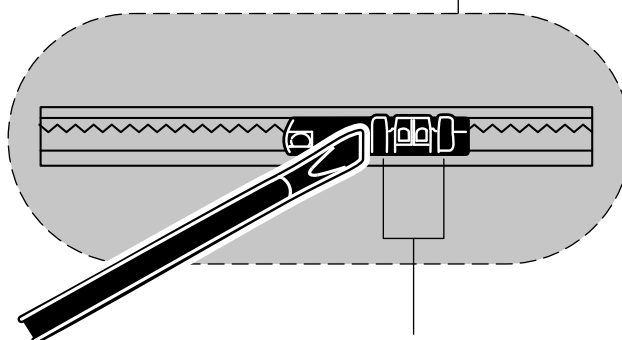
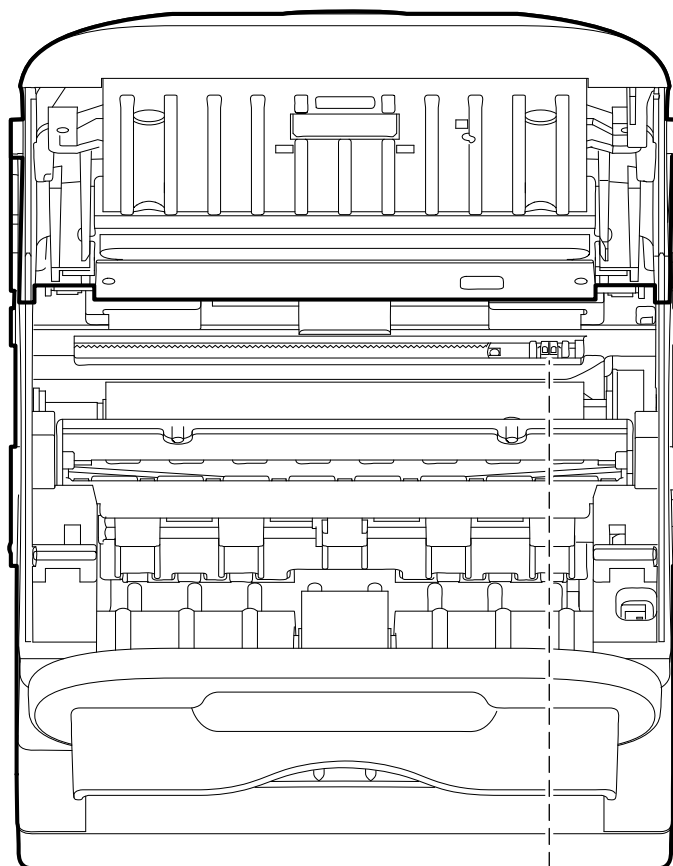

ATTENTION:
To avoid damaging the sensor,
use the plastic tabs as foothold
for the screwdriver to push
the sensor in the desired position.

5.7 Switch the device ON

VKP80III RX65 LAT

1

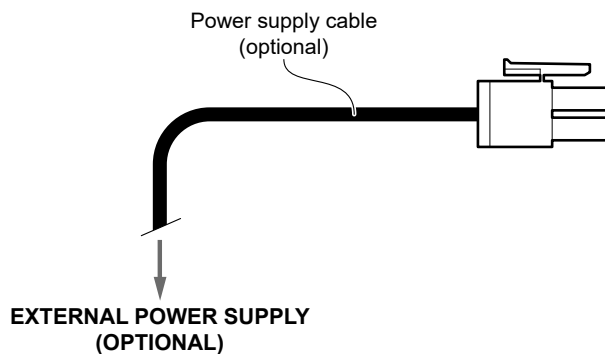

Connect the power supply cable to an external power supply unit.

2

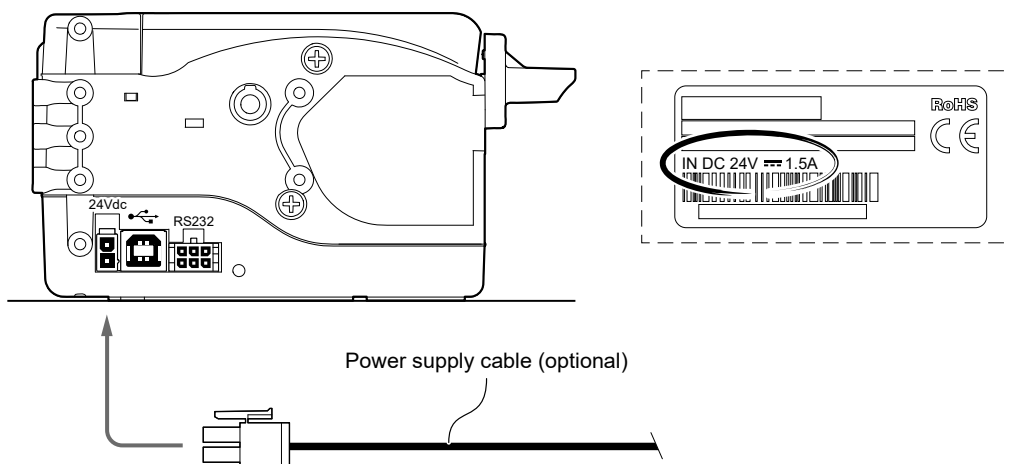

Connect the power supply cable to the device.
Use the type of electrical power supply indicated on the label.

3

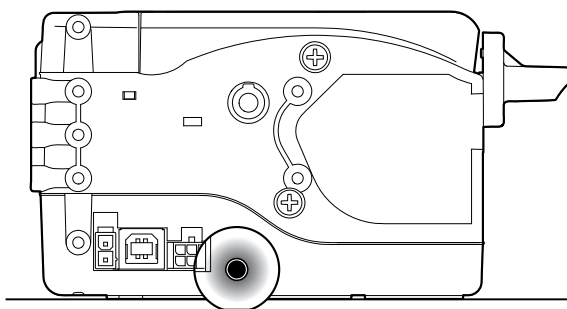

The green status LED turns on and the device is ready.

VKP80III RX65 REAR

1

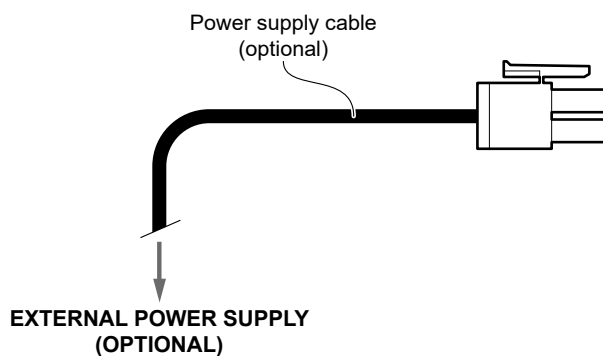

Connect the power supply cable to an external power supply unit.

2

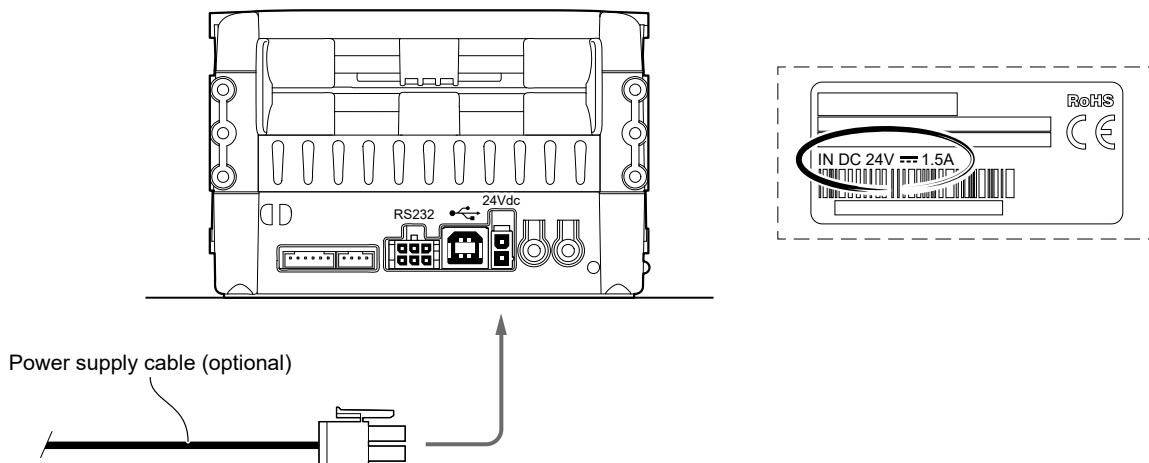

Connect the power supply cable to the device.
Use the type of electrical power supply indicated on the label.

3

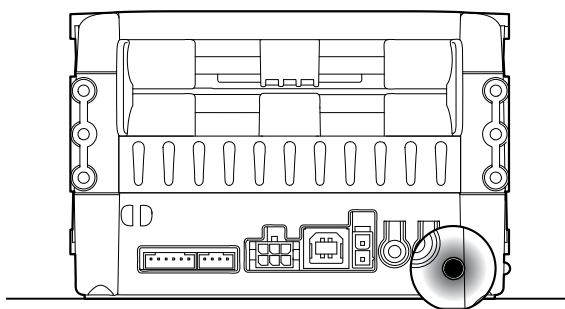

The green status LED turns on and the device is ready.

1

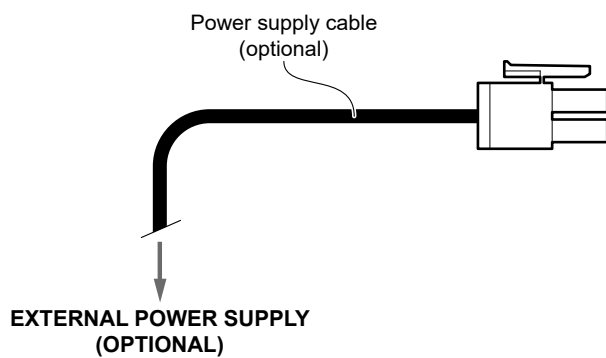

Connect the power supply cable to an external power supply unit.

2

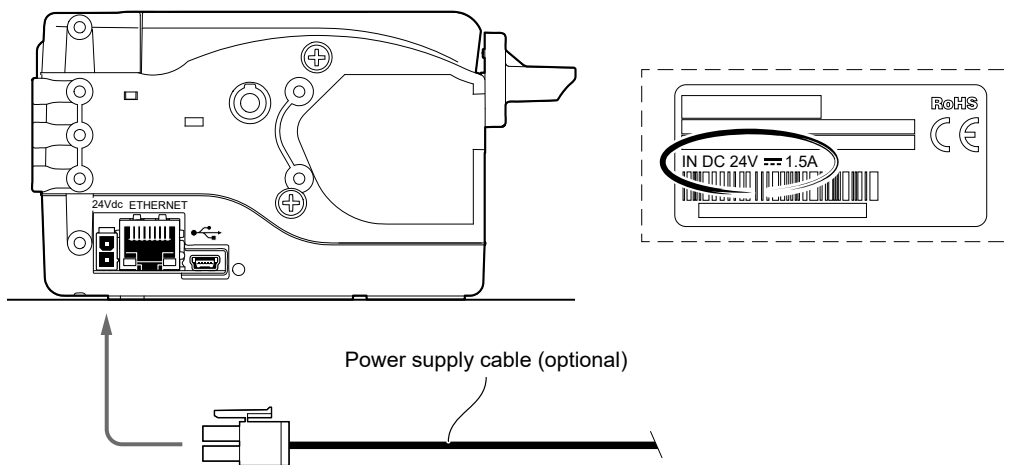

Connect the power supply cable to the device.
Use the type of electrical power supply indicated on the label.

3

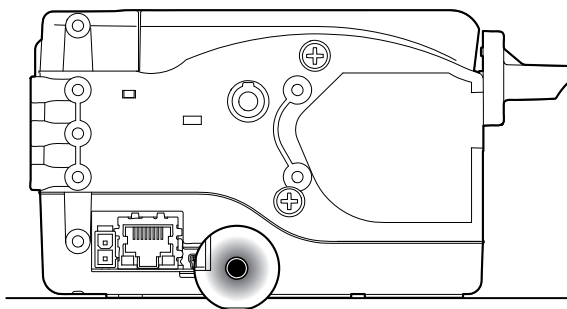

The green status LED turns on and the device is ready.

5.8 Loading the paper roll

At every change of paper, check inside the device. To change the paper proceed as follows.

1

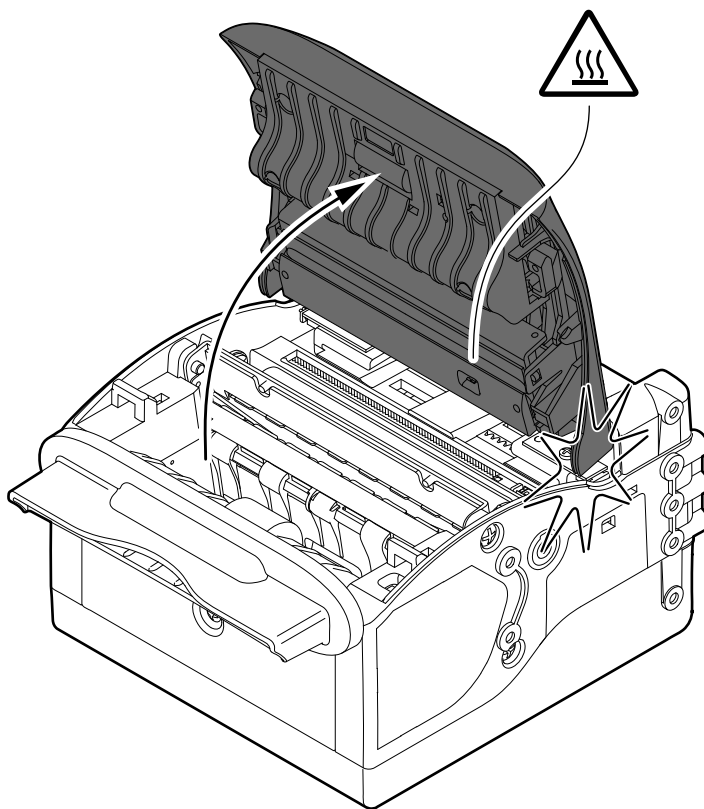

Open the device cover
(see [paragraph 5.1](#)).

2

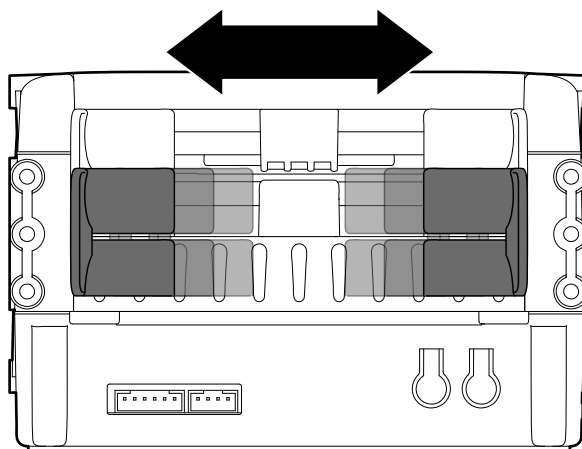

Adjust the paper width
(see [paragraph 5.2](#)).



3

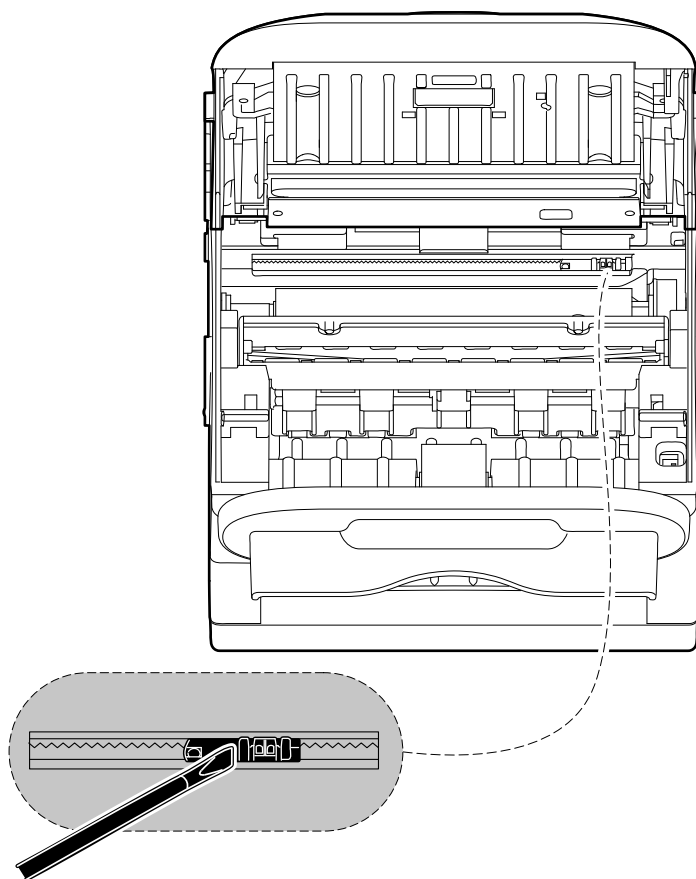

Adjust the mobile sensor position
(see [paragraph 5.6](#)).

4

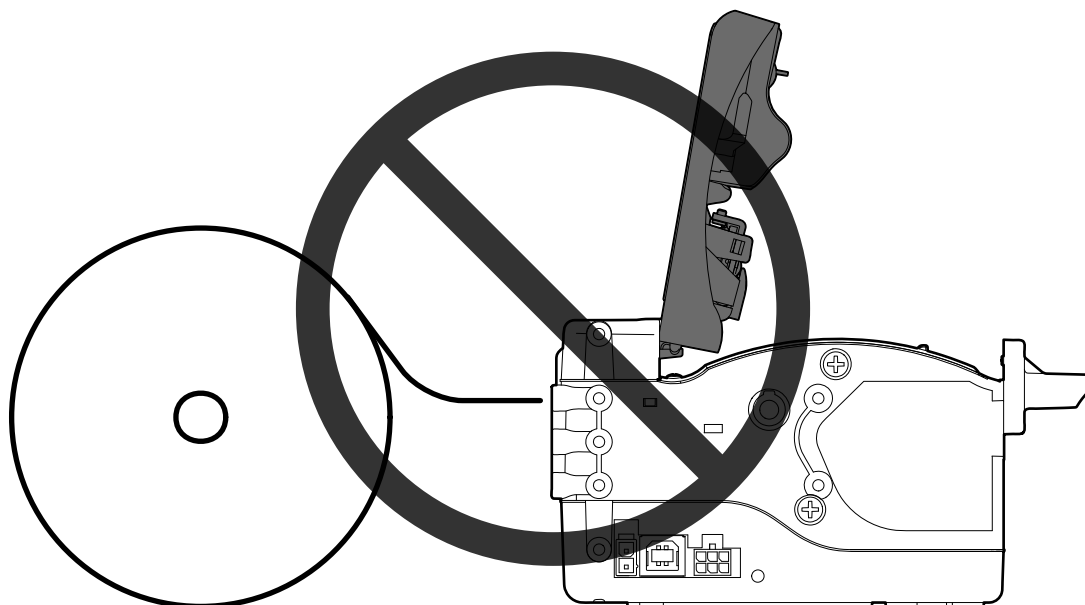

ATTENTION !!!
Do not load the paper with the device cover open.

5

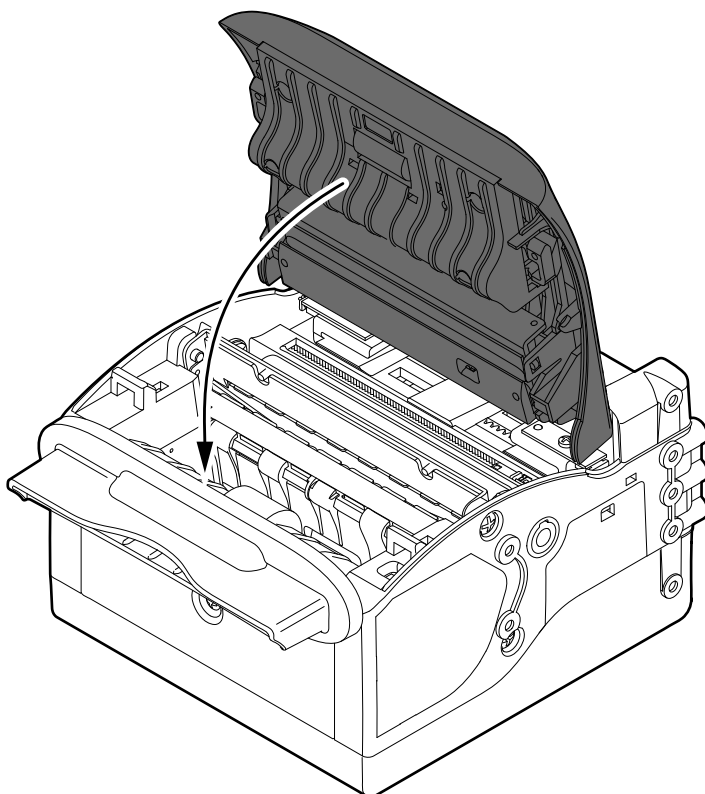

Close the device cover.

6

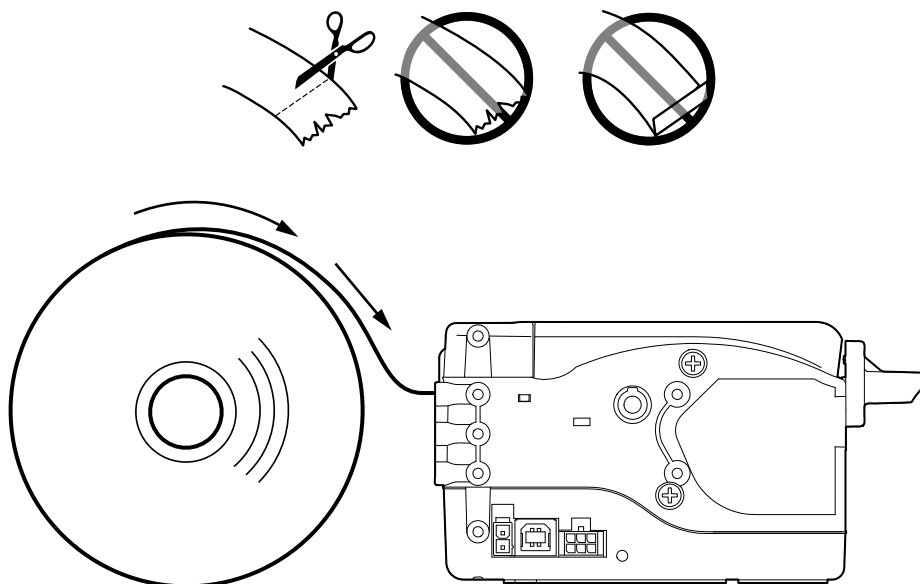

Insert the paper into the input mouth so that it unrolls correctly.
Be sure that the paper is correctly positioned into paper guides.

7

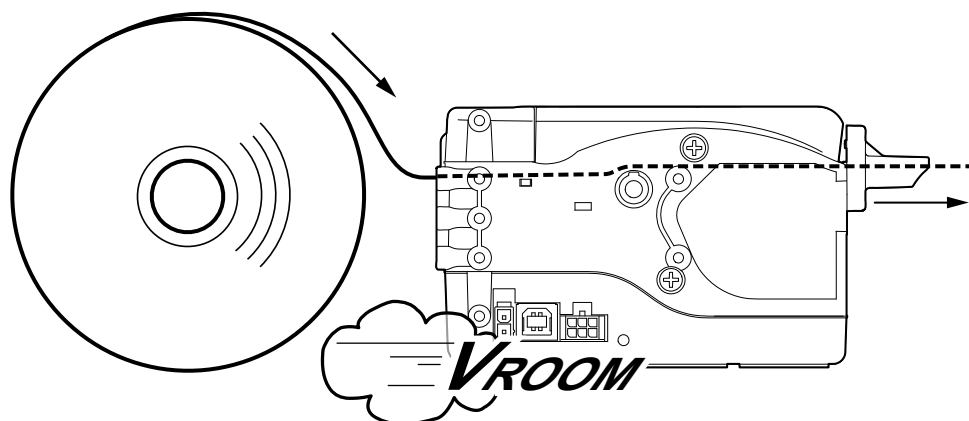

Wait until the paper is
automatically loaded and cut.



The following figure gives the limit positions of the paper roll related to the printer for a correct paper loading without a paper roll holder support.

The direction of the paper will always form a maximum angle of 90° or -90° with the insertion plane of paper inside the printer.

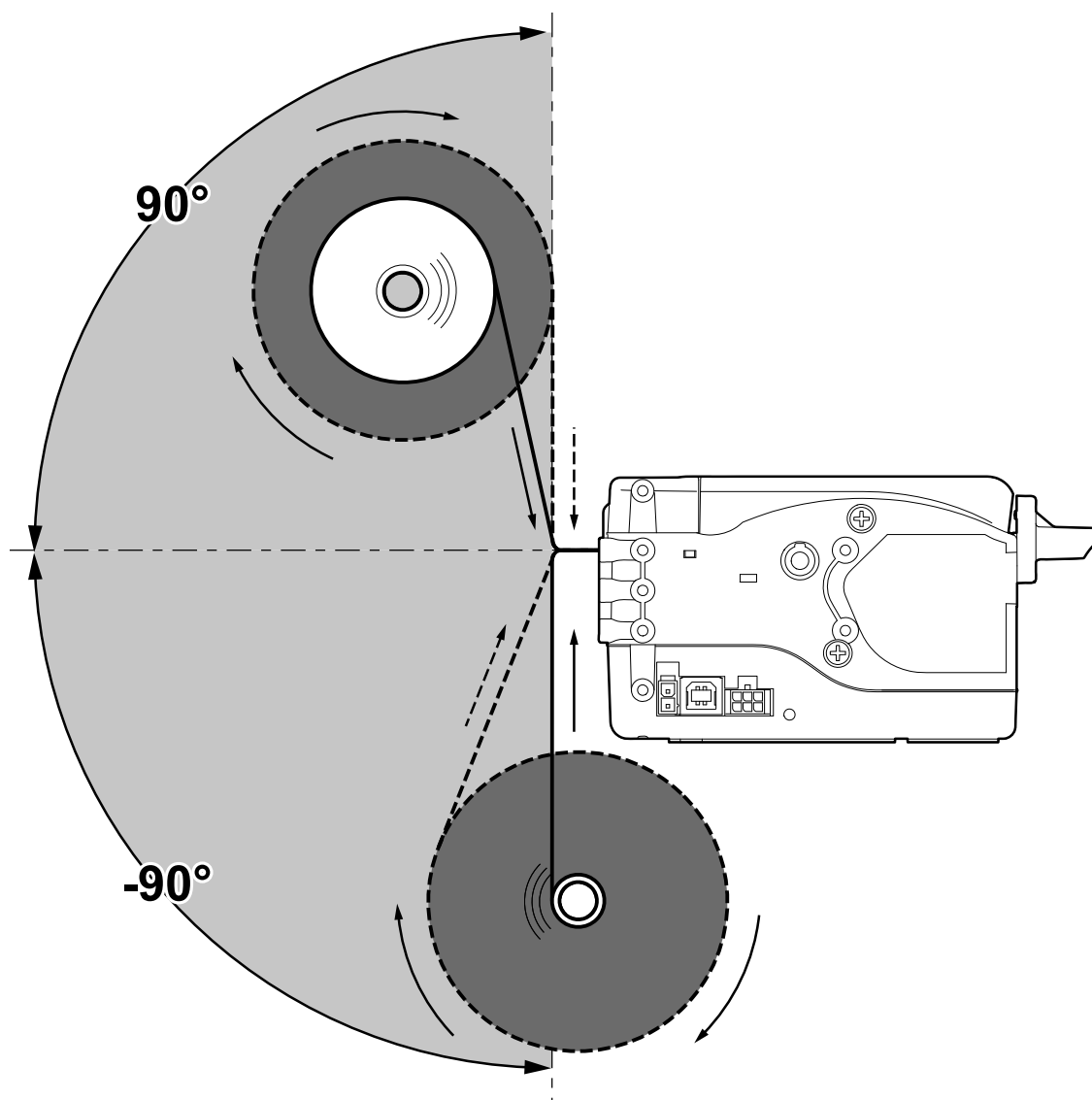

5.9 Issuing ticket

The device allows you to choose between different operating modes for the issuance of printed tickets. The operating modes shown in the following images, depend on the settings of the configuration parameters and commands sent to the device.

“EJECT” mode

1

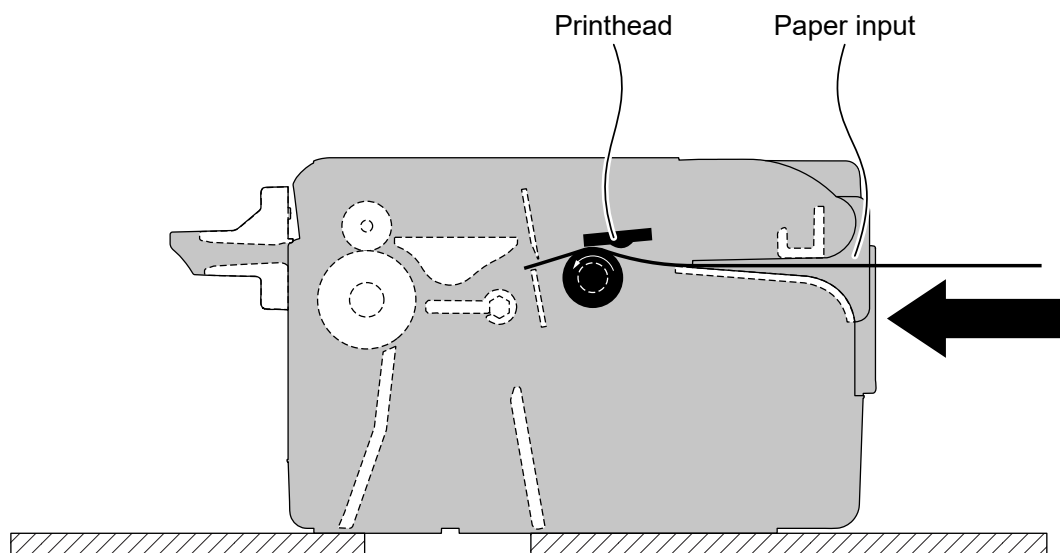

The device starts the ticket printing.

2

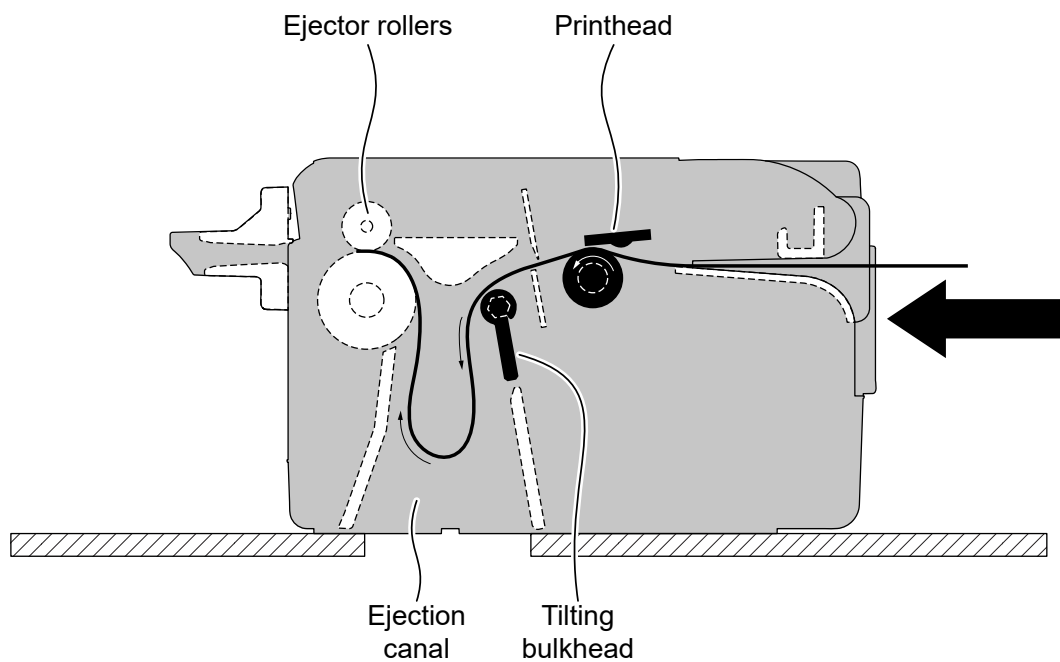

The ticket advances ahead to the ejector and is caught between the ejector rollers. The tilting bulkhead is lowered to allow the ticket portion already printed to be collected in the ejection channel while the device continues printing.

3

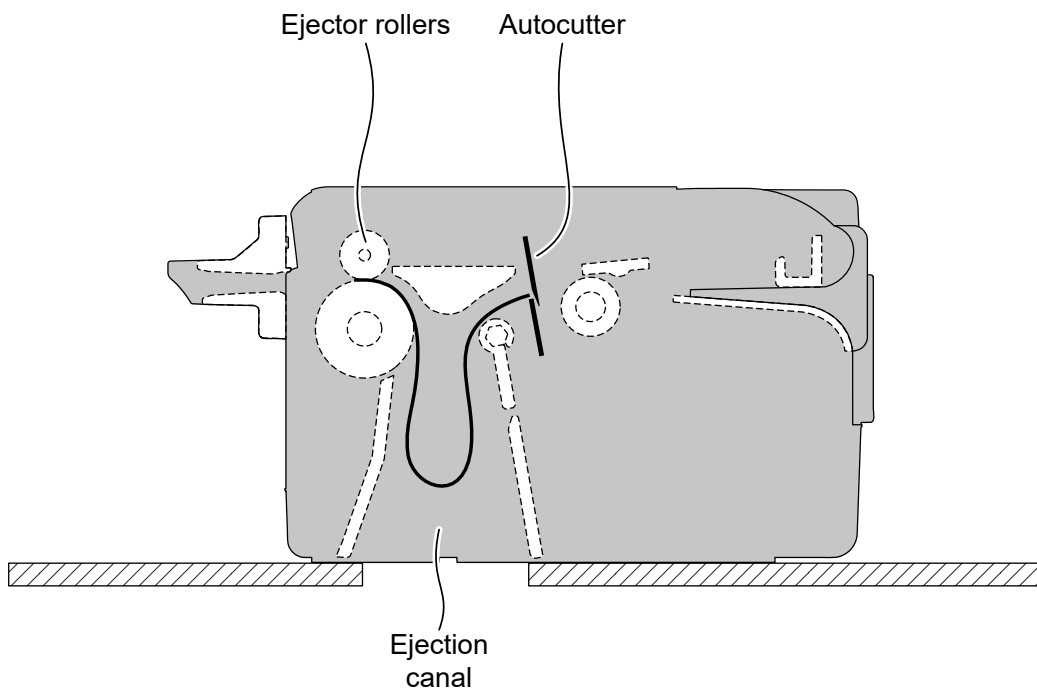

When printing ends, the device cuts the ticket printed.

4

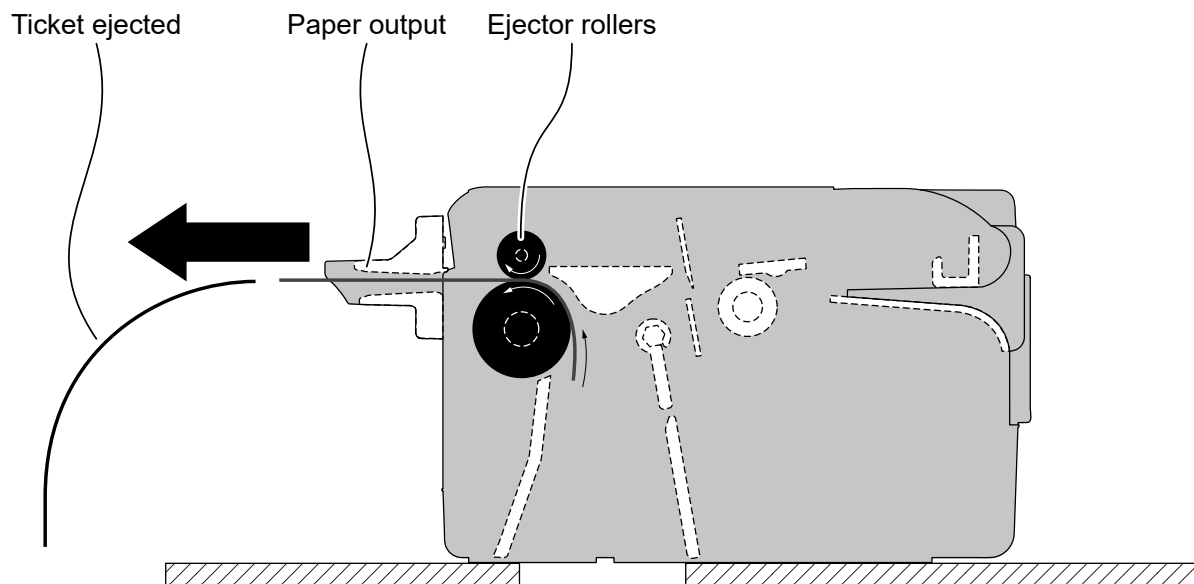

The device directly ejects the ticket.

1

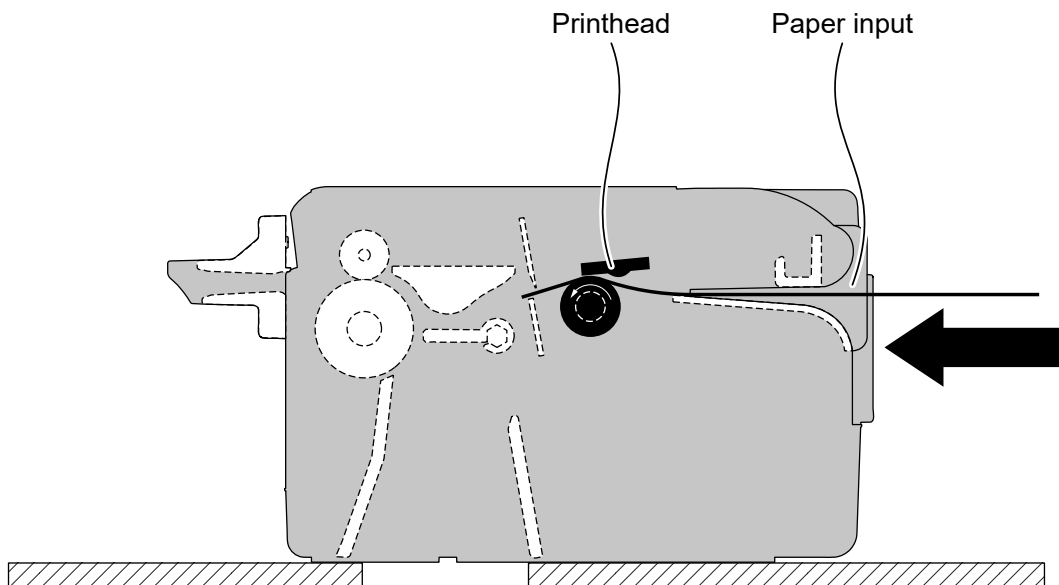

The device starts the ticket printing.

2

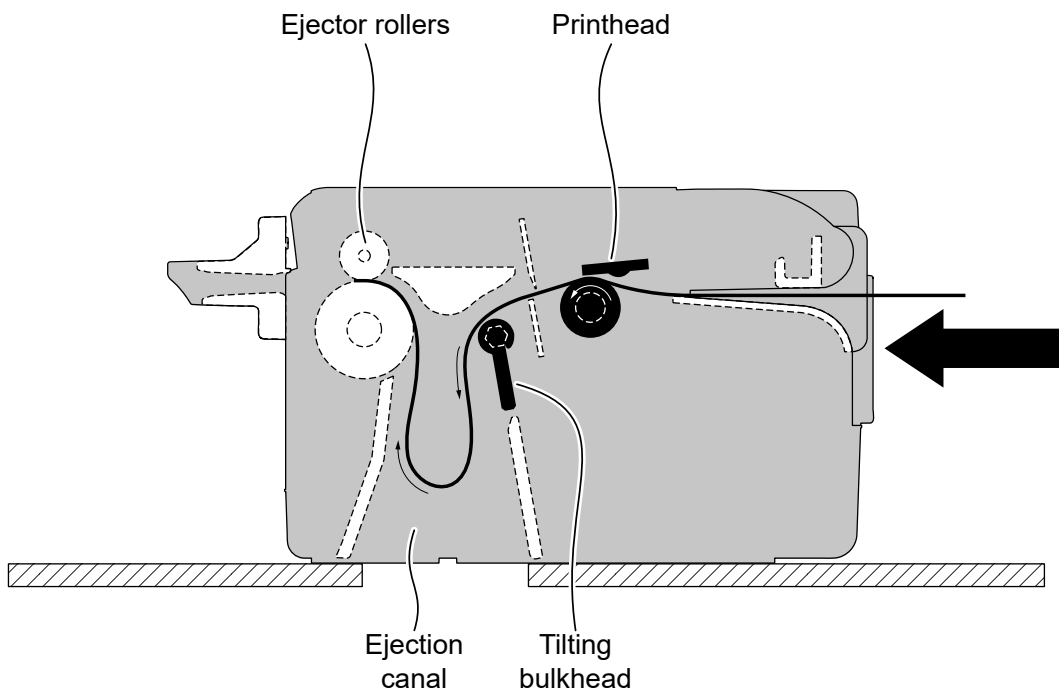

The ticket advances ahead to the ejector and is caught between the ejector rollers. The tilting bulkhead is lowered to allow the ticket portion already printed to be collected in the ejection channel while the device continues printing.

3

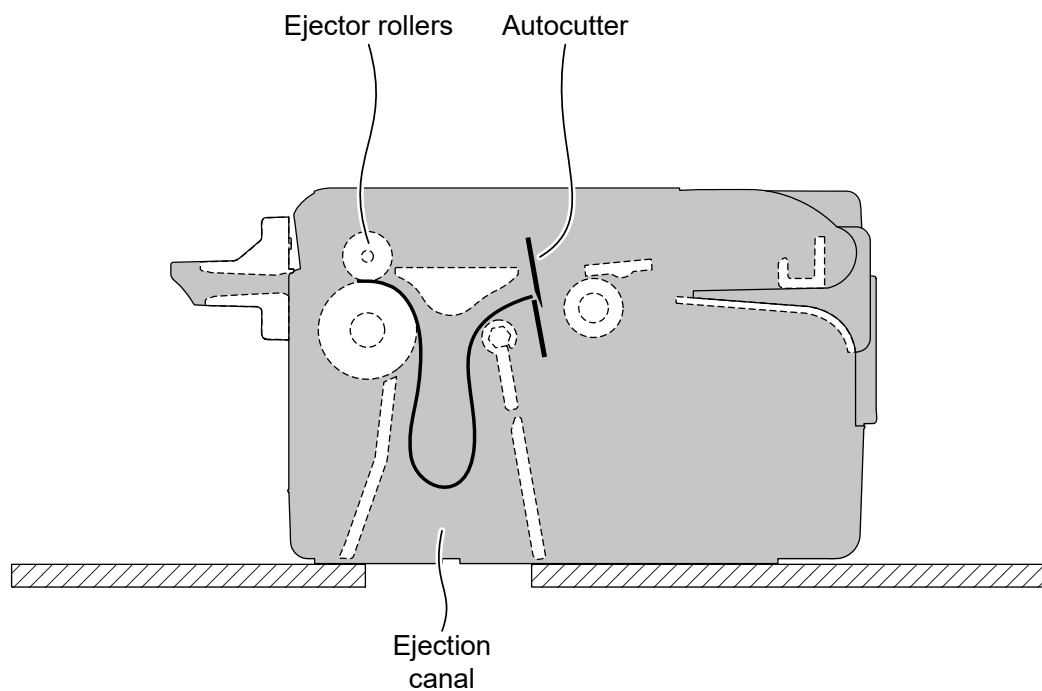

When printing ends, the device cuts the ticket printed.

4

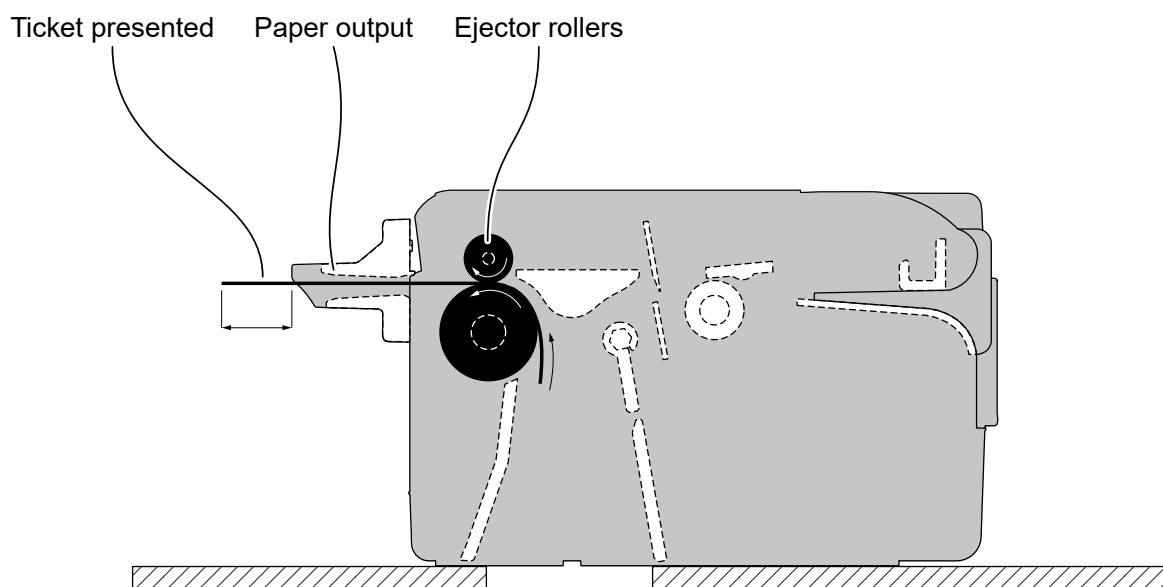

The device presents a portion of the ticket printed on the paper mouth.

5

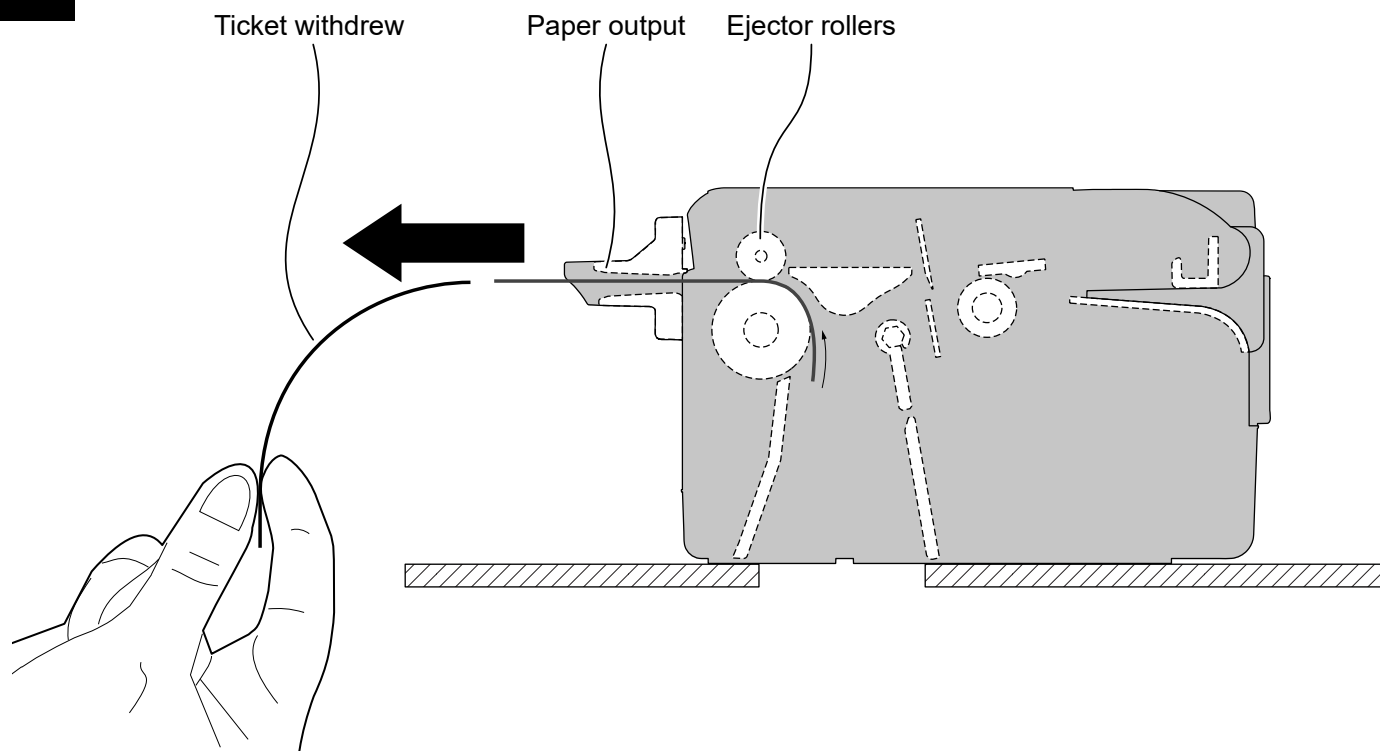

The user withdraw the ticket from the paper mouth.

“PRESENT/RETRACT” mode

1

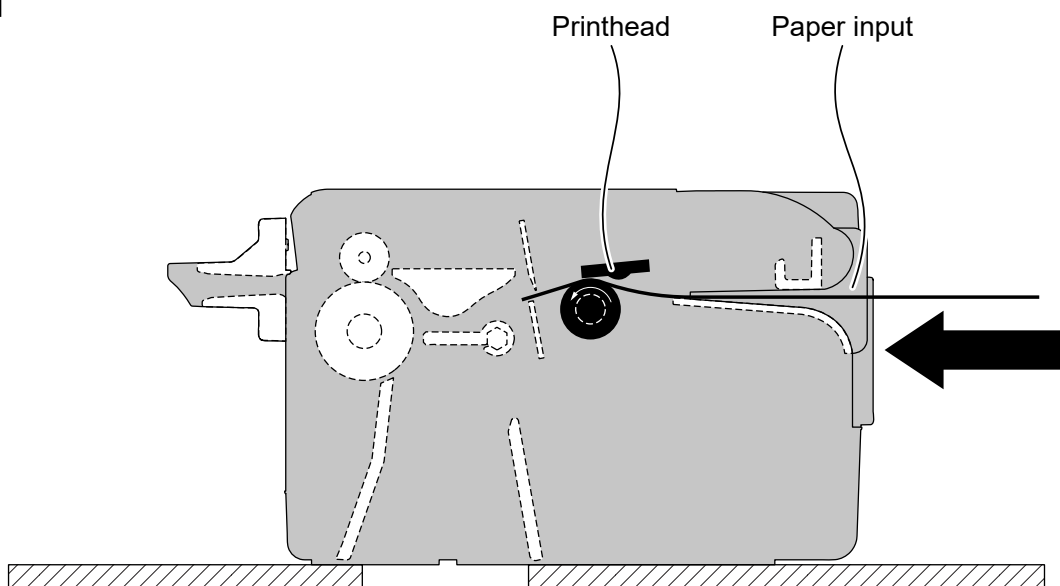

The device starts the ticket printing.

2

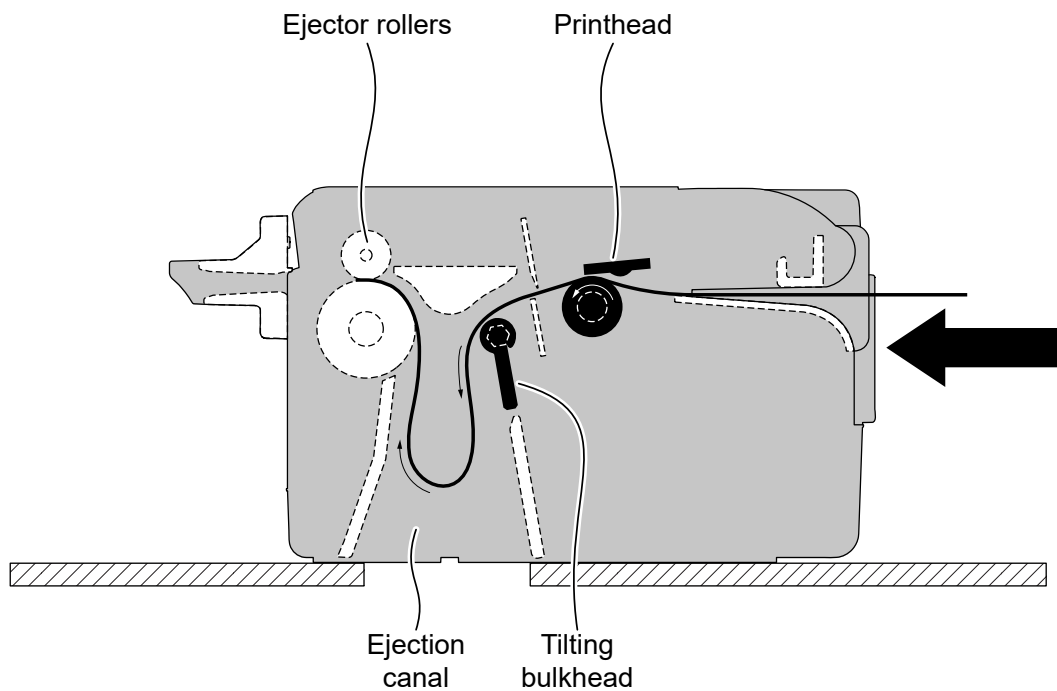

The ticket advances ahead to the ejector and is caught between the ejector rollers. The tilting bulkhead is lowered to allow the ticket portion already printed to be collected in the ejection channel while the device continues printing.

3

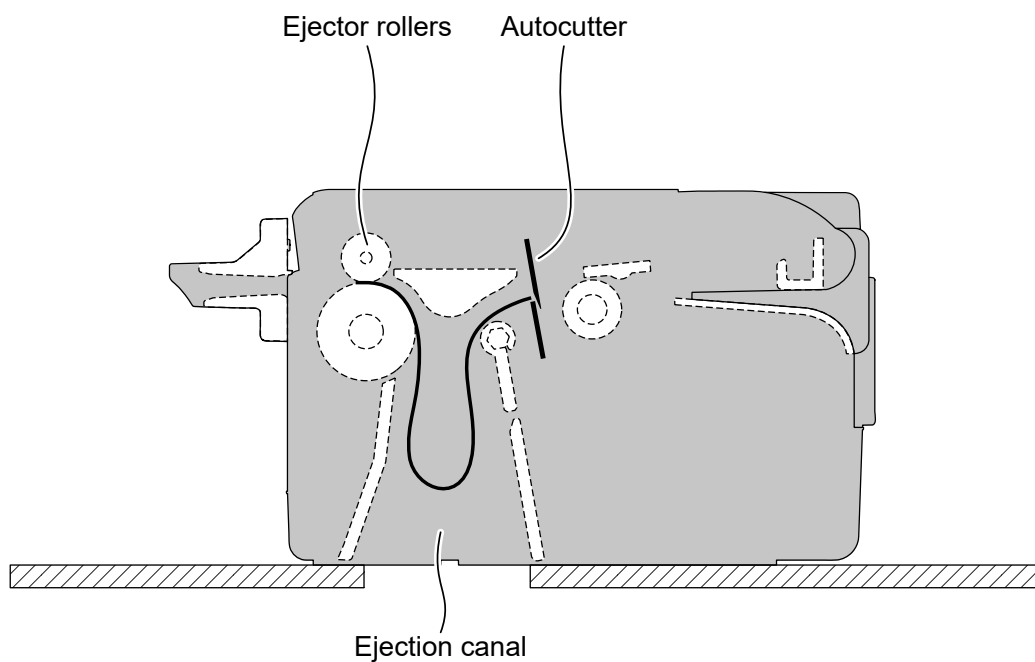

When printing ends, the device cuts the ticket printed.

4

Ticket presented Paper output Ejector rollers

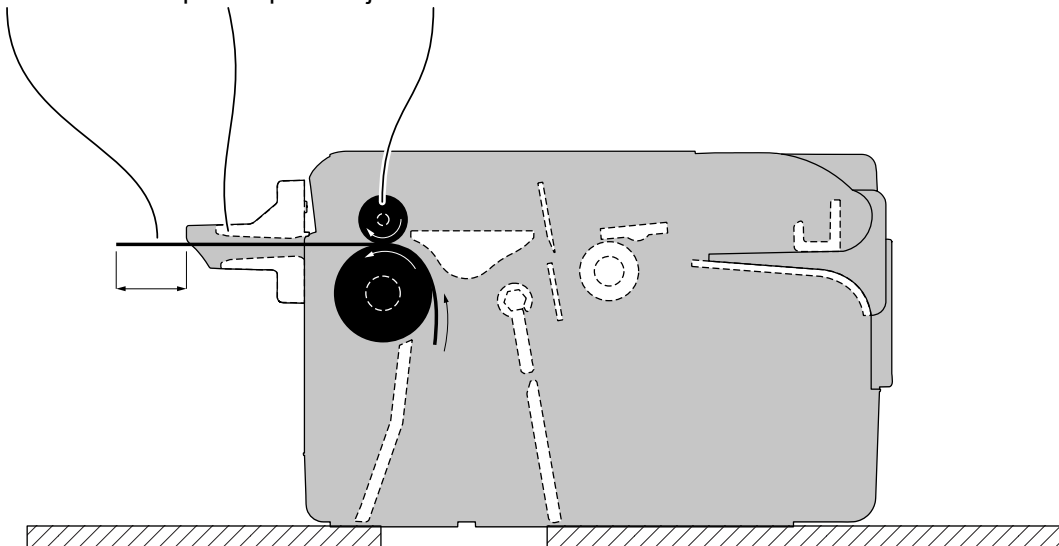

The device presents a portion of the ticket printed on the paper mouth.

5

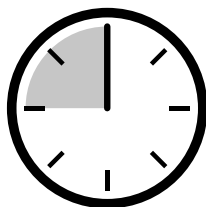

The ticket is waiting on the paper mouth for a preset period of time.

6

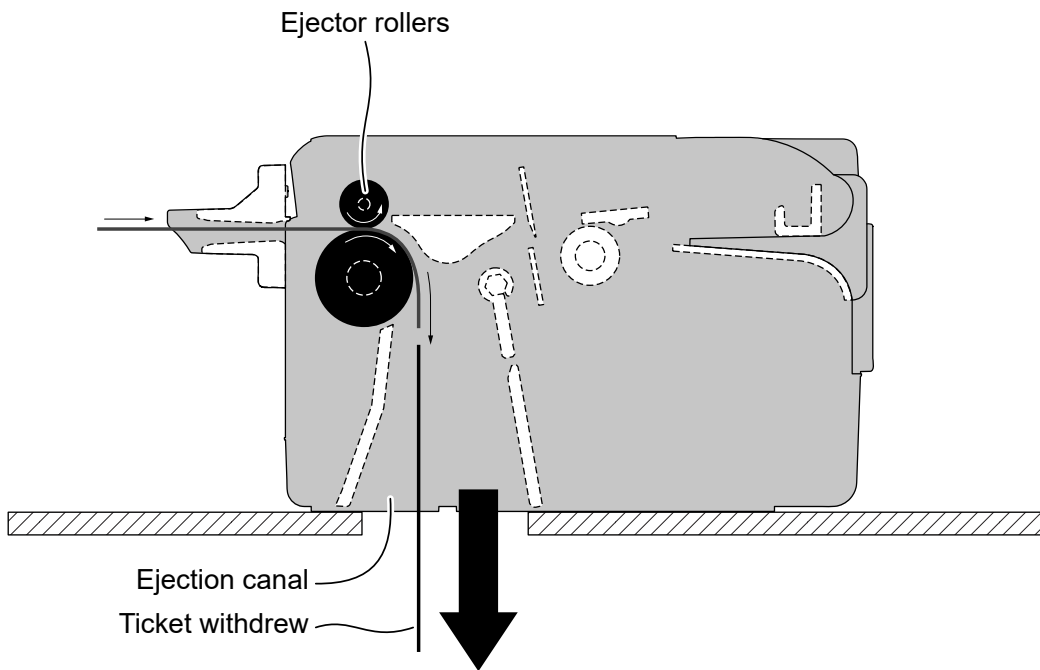

The device retracts and collects the ticket from the mouth paper.

“COLLECT” mode

1

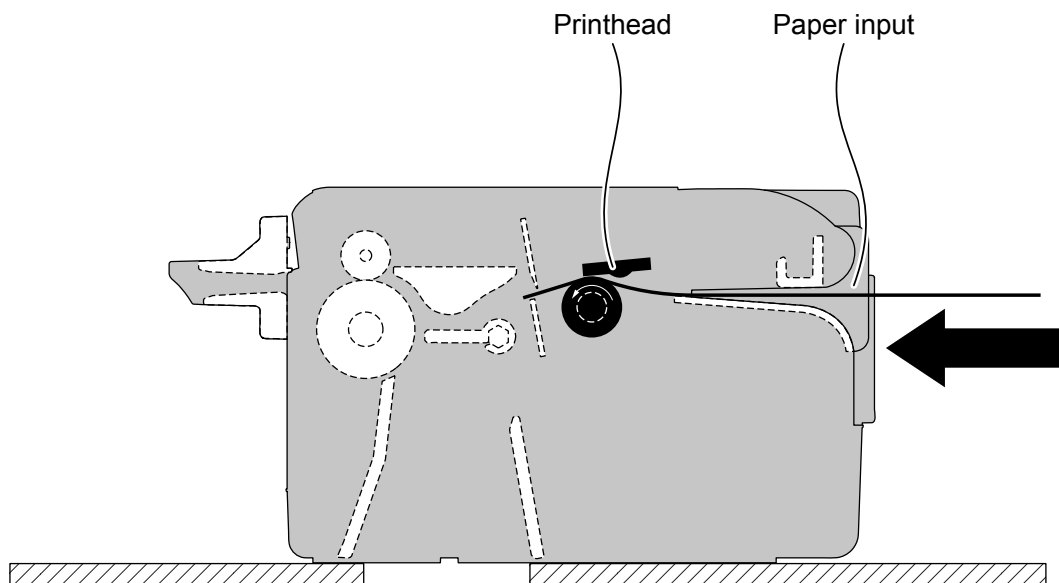

The device starts the ticket printing

2

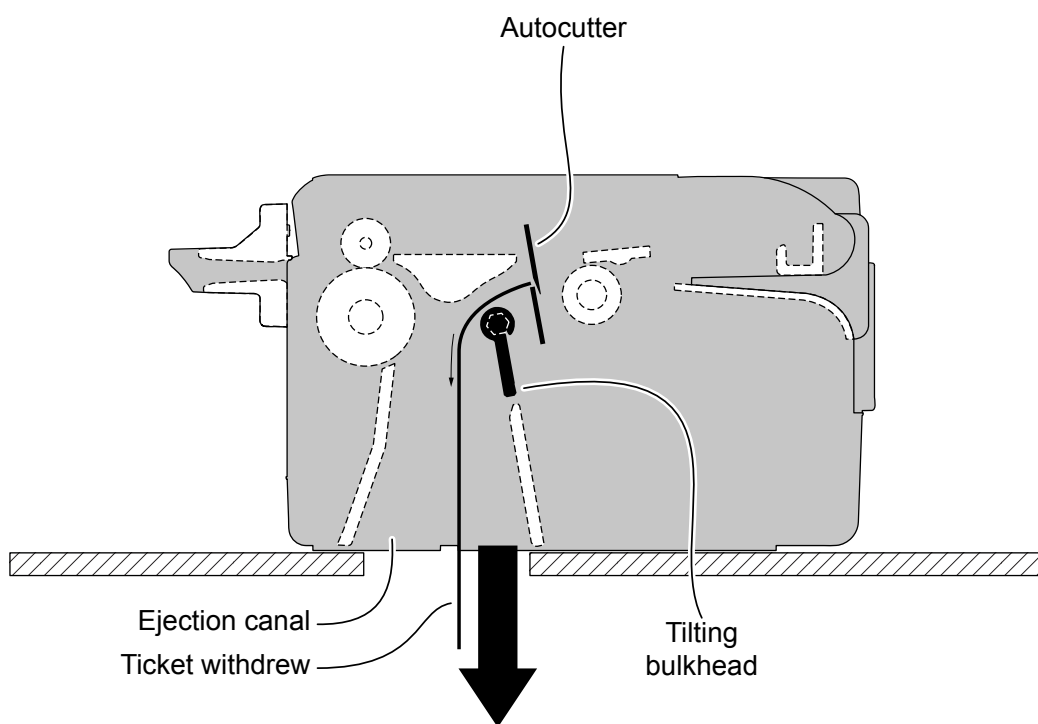

When printing ends, the tilting bulkhead is lowered.
The device cuts and collects the ticket printed without presenting it on the paper mouth.

NOTE:
For further information, refer to the commands manual.



6 CONFIGURATION

6.1 Configuration by software

The setup parameters can be set by using the “PrinterSet” software tool available on www.custom4u.it. For a detailed description of the device operating parameters see the following paragraphs. To configure the device by software, proceed as follows:

1

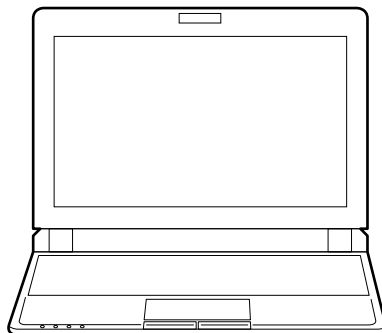

Connect the device to a PC directly (see [paragraph 4.2](#)), without using HUB devices.

2

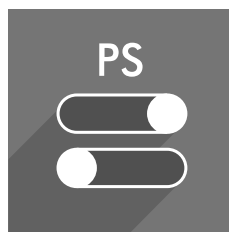

Start “PrinterSet” software tool.

3

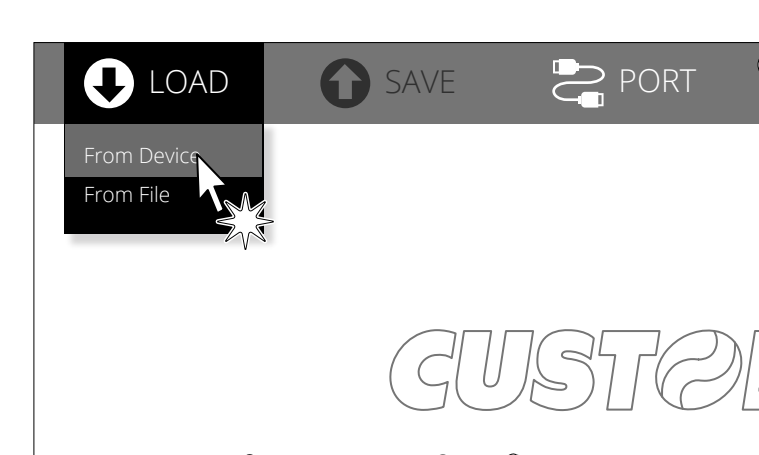

Click on LOAD > FROM DEVICE and select the device connected to the PC.

4

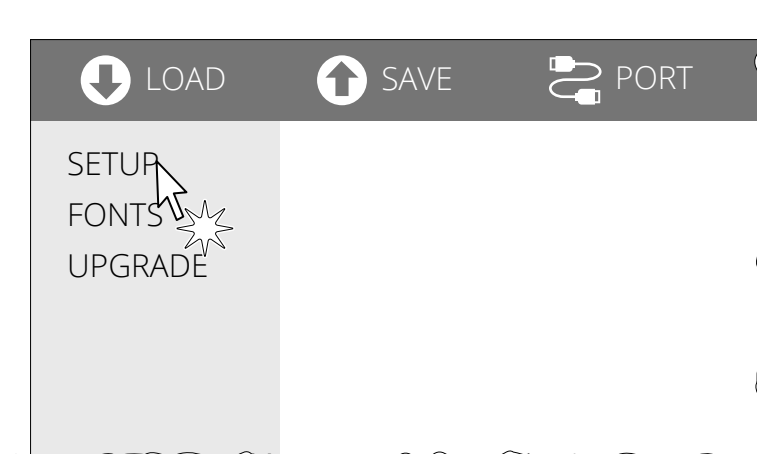

Click on SETUP to access the operating parameters of the device to be configured.

5

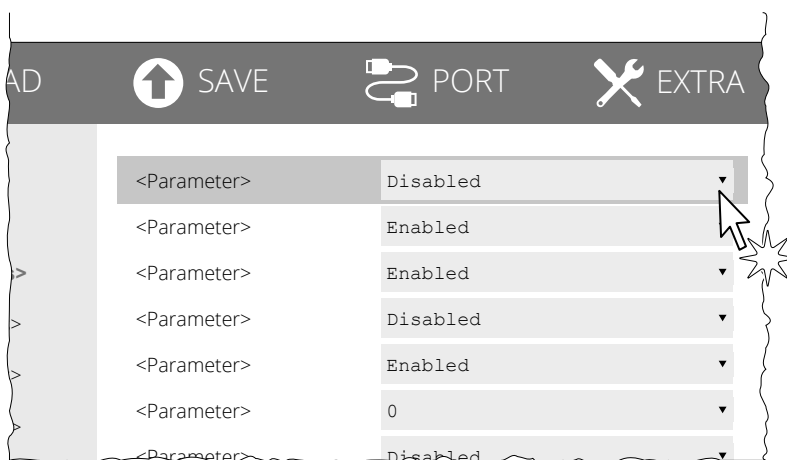

Make the desired changes to the device operating parameters.

6

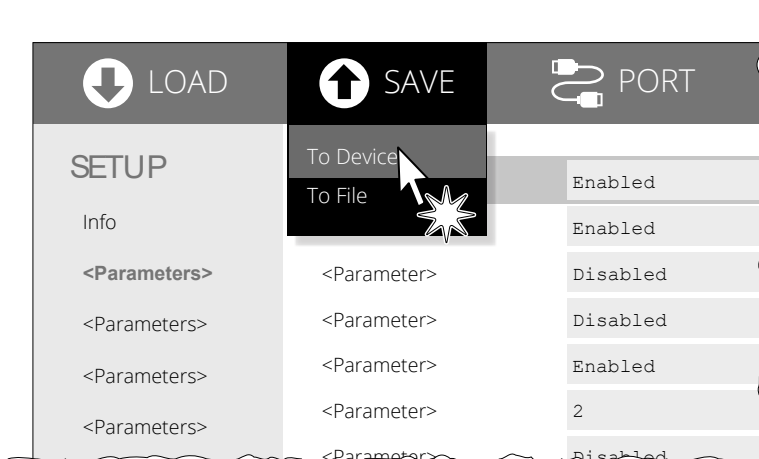

Click on SAVE > TO DEVICE to make the changes made effective.

ATTENTION:

During saving, it is strongly discouraged to disconnect the communication cable or to remove the power supply of the PC or the device.

6.2 Configuration by keys

To enter the configuration mode and print a setup report with the operating parameters of the device, proceed as follows.

VKP80III RX65 LAT, VKP80III ETH

1

While pressing the LINE FEED key, switch on the device by inserting the power supply cable.

2

The device prints the report with settings parameters.

3

Enter setup

Press the LINE FEED key to enter the configuration mode.

VKP80III RX65 REAR

1

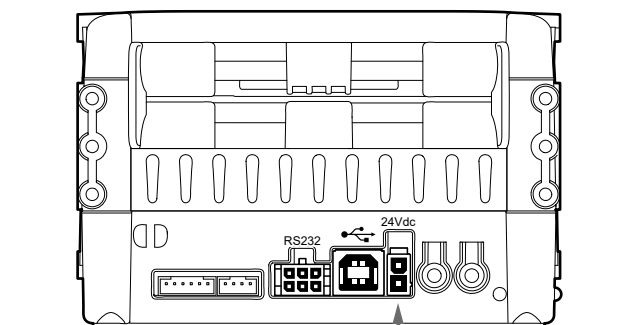
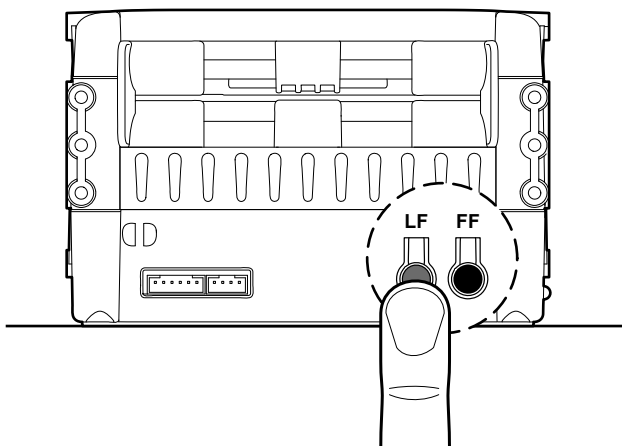

Power supply cable
(optional)



While pressing the LINE FEED key,
switch on the device by inserting the power supply
cable.

2

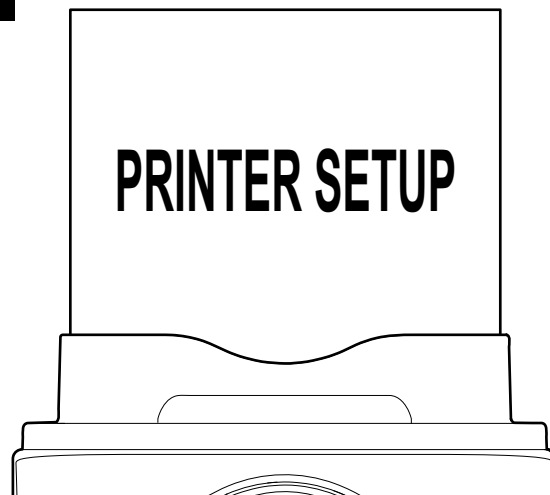

The device prints the report with
settings parameters.

3

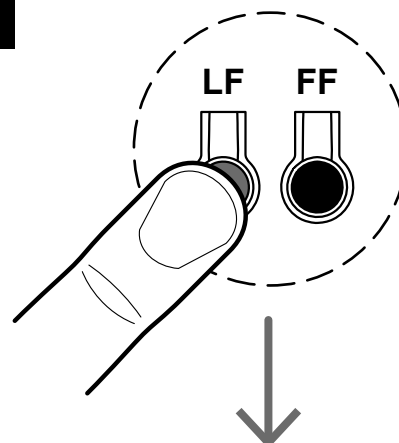

**Enter
setup**

Press the LINE FEED key to enter
the configuration mode.



The following figure shows the setup report of the device. The shown values for parameters are sample values; for the list and the description of device parameters see the following paragraphs.

VKP80III RX65 LAT, VKP80III RX65 REAR

DEVICE NAME AND
FIRMWARE MODULES
RELEASE

```

      < device name >
SCODE: <code>           - rel 1.00
DCODE: <code>           - rel 1.00
FCODE: <code>           - rel 1.00
  
```

PRINTING HEAD
STATUS

```

          PRINTER SETTINGS
          1 «*****» 640
-----
          PRINthead WORKING GOOD!
  
```

DEVICE
STATUS

```

PRINTER TYPE .....<device model>
LED bar RGB (hardware).....Present
PRINTING HEAD TYPE.....<head model>
INTERFACE .....USB
PROGRAM MEMORY TEST.....OK
DYNAMIC RAM TEST.....OK
EXTERNAL MEMORY TEST .....OK
CUTTER TEST.....OK
HEAD VOLTAGE           [V]  = 23.37
HEAD TEMPERATURE      [°C] = 25
POWER ON COUNTER      = 72
PAPER PRINTED         [cm] = 6220
CUT COUNTER            = 2218
RETRACT COUNTER       = 95
COVER OPEN COUNTER    = 104
  
```

PARAMETERS
FOR DEVICE
CONFIGURATION

```

Printer Emulation.....: VKP80 III
RS232 Baud Rate .....: 115200 bps
RS232 Data Length.....: 8 bits/chr
RS232 Parity .....: None
RS232 Handshaking .....: Hardware
Busy Condition .....: RxFull
USB Class .....: Printer
USB Address Number .....: 0
Print Mode .....: Normal
Autofeed .....: CR Disabled
Code Table [num] .....: 0
Font Type.....: International
Chars / inch .....: A=15 B=20 cpi
Speed / Quality.....: Normal
Print Width .....: 80 mm
Paper Threshold .....: 40%
Black Mark Position .....: Bottom
Black Mark Threshold.....: 40%
Black Mark Distance [mm].....: +00.0
PaperEnd Buffer Clear .....: Enabled
PrintHead Test PowerOn.....: Disabled
Data Logger.....: Disabled
Sleep Time [min].....: Disabled
Line Space Reduction .....: Disabled
Line Feed Reduction .....: Disabled
Barcode Height Reduc. ....: Disabled
Print Density.....: 0%
  
```

KEYS FUNCTIONS

```

[ LF ] enter Printer setup
[ FF ] skip Setup
  
```



DEVICE NAME AND
FIRMWARE MODULES
RELEASE

```

< device name >
SCODE: <code>           - rel 1.00
DCODE: <code>           - rel 1.00
FCODE: <code>           - rel 1.00

```

PRINTING HEAD
STATUS

PRINTER SETTINGS

1 «*****» 640

PRINthead WORKING GOOD!

DEVICE
STATUS

```

PRINTER TYPE .....<device model>
LED bar RGB (hardware) .....Present
PRINTING HEAD TYPE .....<head model>
INTERFACE .....USB
PROGRAM MEMORY TEST.....OK
DYNAMIC RAM TEST.....OK
EXTERNAL MEMORY TEST .....OK
CUTTER TEST.....OK
HEAD VOLTAGE           [V]  = 23.37
HEAD TEMPERATURE      [°C] = 25
POWER ON COUNTER      = 72
PAPER PRINTED         [cm] = 6220
CUT COUNTER           = 2218
RETRACT COUNTER       = 95
COVER OPEN COUNTER    = 104

```

ETH. SPEED = 10 Mb/s Half-Duplex MDIX

DHCP Client : **Disabled**

IP Address : **10. 10. 54. 26**

Subnet Mask : **255. 255. 240. 0**

Default Gateway : **10. 10. 54. 254**

MAC Address : **00-0E-E2-0D-5F-74**

PARAMETERS
FOR DEVICE
CONFIGURATION

```

Printer Emulation..... : VKP80 III
USB Class ..... : Printer
USB Address Number ..... : 0
Print Mode ..... : Normal
Autofeed ..... : CR Disabled
Code Table [num] ..... : 0
Font Type..... : International
Chars / inch ..... : A=15 B=20 cpi
Speed / Quality..... : Normal
Paper Threshold ..... : 40%
Black Mark Position ..... : Bottom
Black Mark Threshold ..... : 40%
Black Mark Distance [mm]..... : +00.0
PaperEnd Buffer Clear ..... : Enabled
PrintHead Test PowerOn ..... : Disabled
Data Logger..... : Disabled
Sleep Time [min]..... : Disabled
Print Density ..... : 0%

```

KEYS FUNCTIONS

```

[ LF ] enter Printer setup
[ FF ] skip Setup

```

6.3 Configuration by file

The setup parameters can be set by editing the "Setup.ini" file stored on the Flash Drive of the device. Proceed as follows:

1

↓

Enter setup

Enter the configuration procedure by keys (see [paragraph 6.2](#)) or by software (see [paragraph 6.1](#)).

2

<parameter> : <value>
<parameter> : <value>
<parameter> : <value>
<parameter> : <value>
<parameter> : <value>
USB Class : Mass Storage
<parameter> : <value>
<parameter> : <value>
<parameter> : <value>
<parameter> : <value>

Check that the "USB Class" parameter is set to "Mass Storage". Otherwise, this configuration mode is not available.

3

USB

↓

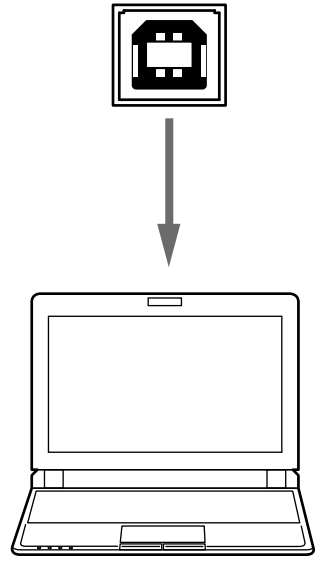

Plug the device to a Personal Computer via USB.

4

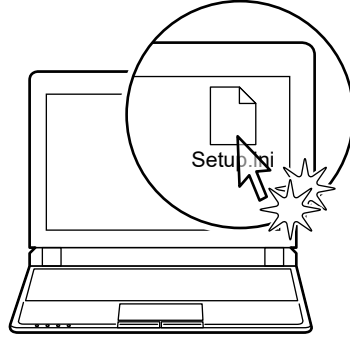

Enter the Flash drive of the device and edit the "Setup.ini" file.



The "Setup.ini" file is a configuration file that contains all the configurable parameters listed in text format and divided into some sections (indicated between square brackets). For each parameter, you find the parameter name followed by the value currently set and then the available values listed with a reference number. The reference number marked with the symbol ' * ' is the default one (see figure).

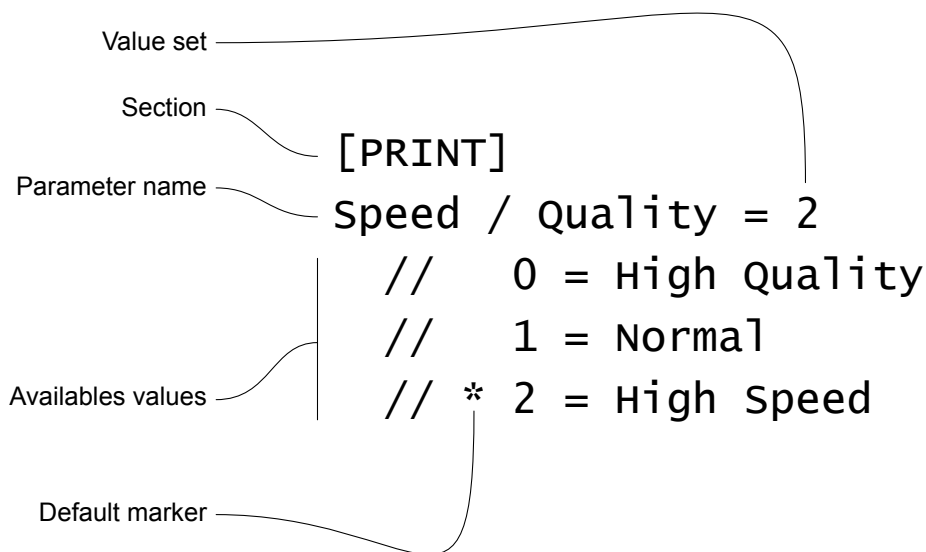

To modify the parameter, change the numeric value after the parameter name or use the default value by typing "D". After editing device's parameter, simply save the "Setup.ini" file to make the modifies activated. For a detailed description of the device operating parameters see the following paragraphs.

ATTENTION:

The change of value for the "USB Class" parameter may compromise the access to the Setup.ini file. Be careful to keep the "Mass Storage" value to allow a new access to the Flash Drive.



6.4 Printhead status

The device performs the printhead operating status when printing the setup report. The total number of dots is reported. Are indicated the total dots number of the printhead and their status (see figure below).

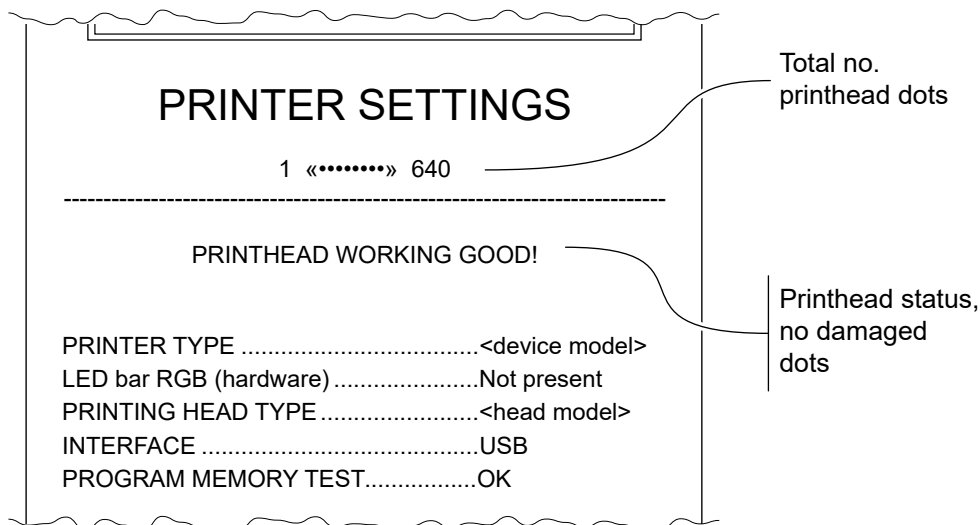

In case of damaged dots, these are listed in the print out in according to their position on the heating line (see figure below).

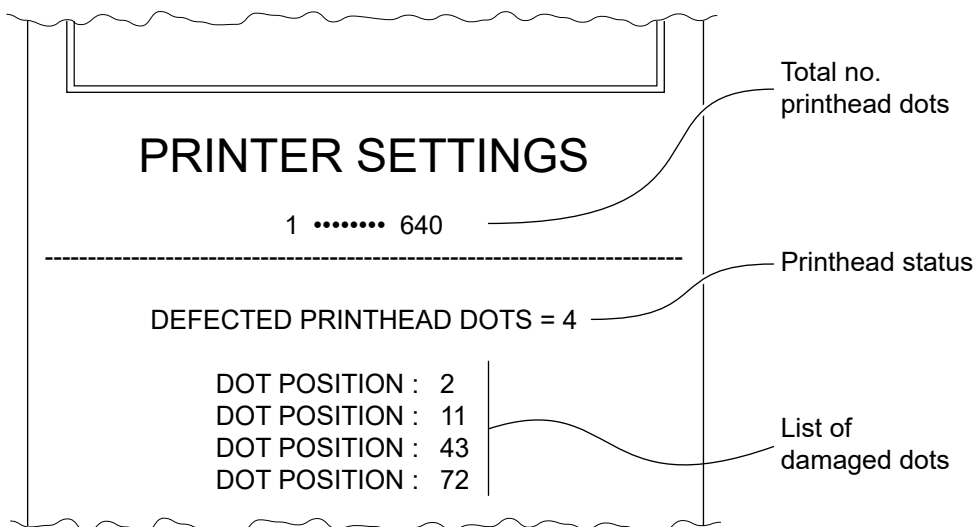



6.5 Device status

The printer operating status is indicated in the configuration print-out in which, next to the name of the components displayed, the following information is given:

PRINTER TYPE	device model
LED BAR RGB (hardware)	presence of the board for managing the RGB LED bar
PRINTING HEAD TYPE	print head model
INTERFACE	interface present
PROGRAM MEMORY TEST	OK appears if functioning and NOT OK if faulty
DYNAMIC RAM TEST	OK appears if functioning and NOT OK if faulty
EXTERNAL MEMORY TEST	OK appears if functioning and NOT OK if faulty
CUTTER TEST	OK appears if functioning and NOT OK if faulty
HEAD VOLTAGE	voltage of the head
HEAD TEMPERATURE	temperature of the head
POWER ON COUNTER	number of power-ups made
PAPER PRINTED	centimetres of paper printed
CUT COUNTER	number of cuts made
RETRACT COUNTER	number of “retracts” made
COVER OPEN COUNTER	number of cover opening made



6.6 Communication parameters

The device allows the configuration of the parameters listed in the following table.

The parameters marked with the symbol ^D are the default values.

Settings remain active even after the device has been turned off and they are stored in non-volatile memory.

RS232 BAUD RATE	Communication speed of the serial interface:
	1200 9600 57600
	2400 19200 115200 ^D
	4800 38400
	This parameter is valid only for VKP80III RX65 LAT and VKP80III RX65 REAR with serial interface.
RS232 DATA LENGTH	Number of bit used for characters encoding:
	7 bits/car 8 bits/car ^D
	This parameter is valid only for VKP80III RX65 LAT and VKP80III RX65 REAR with serial interface.
RS232 PARITY	Bit for the parity control of the serial interface:
	None ^D = parity bit omitted
	Even = even value for parity bit
	Odd = odd value for parity bit
	This parameter is valid only for VKP80III RX65 LAT and VKP80III RX65 REAR with serial interface.
RS232 HANDSHAKING	Handshaking:
	XON/XOFF = software handshaking
	Hardware ^D = hardware handshaking (CTS/RTS)
	This parameter is valid only for VKP80III RX65 LAT and VKP80III RX65 REAR with serial interface.
	When the receive buffer is full, if handshaking is set to XON/XOFF, the device sends the XOFF (0x13) on the serial port. When the receive buffer has cleared once again, if handshaking is set to XON/XOFF, the device sends the XON (0x11) on the serial port.
BUSY CONDITION	Activation mode for Busy signal:
	OffLine/ RXFull = Busy signal is activated when the device is both in OffLine status and the buffer is full
	RXFull ^D = Busy signal is activated when the buffer is full
	This parameter is valid only for VKP80III RX65 LAT and VKP80III RX65 REAR with serial interface.



USB ADDRESS NUMBER	<p>Numerical address code for the univocal identification of the USB device (in case of more than a USB device connected with the same PC):</p> <table><tr><td>0^D</td><td>2</td><td>4</td><td>6</td><td>8</td></tr><tr><td>1</td><td>3</td><td>5</td><td>7</td><td>9</td></tr></table>	0 ^D	2	4	6	8	1	3	5	7	9
0 ^D	2	4	6	8							
1	3	5	7	9							

USB CLASS	<p>USB communication class definition.</p> <p>Printer^D = setting the printer function Mass Storage = setting the sharing mode from Mass Storage Virtual COM = setting the USB port as a virtual serial port</p>
------------------	--

DHCP CLIENT	<p>Setting of the DHCP protocol:</p> <p>Disabled^D = protocol disabled Enabled = protocol enabled</p> <p>This parameter is valid only for VKP80III ETH.</p>
--------------------	---

IP ADDRESS	<p>IP address of device; this parameter is assigned by the network administrator.</p> <p>This parameter is valid only for VKP80III ETH and it can be modified by software (see paragraph 6.1) and by file (see paragraph 6.3).</p>
-------------------	--

SUBNET MASK	<p>This parameter identifies the local network address.</p> <p>This parameter is valid only for VKP80III ETH and it can be modified by software (see paragraph 6.1) and by file (see paragraph 6.3).</p>
--------------------	--

DEFAULT GATEWAY	<p>This parameter identifies the Gateway IP address used to send applications to the external network.</p> <p>This parameter is valid only for VKP80III ETH and it can be modified by software (see paragraph 6.1) and by file (see paragraph 6.3).</p>
------------------------	---

TCP PRINTER PORT	<p>This parameter sets the TCP port number.</p> <p>This parameter is valid only for VKP80III ETH and it can be modified by software (see paragraph 6.1) and by file (see paragraph 6.3).</p>
-------------------------	--

MAC ADDRESS	<p>This is the number, provided by the constructor, that identifies the device; this number is univocal.</p> <p>This parameter is valid only for VKP80III ETH and it can't be modified.</p>
--------------------	---



6.7 Operating parameters

The device allows the configuration of the parameters listed in the following table.

The parameters marked with the symbol ^D are the default values.

Settings remain active even after the device has been turned off and they are stored in non-volatile memory.

PRINTER EMULATION	Available emulations for the device: VKP80III ^D VKP80II
--------------------------	--

PRINT MODE	Printing mode: Normal ^D = enables printing in normal writing way Reverse = enables printing rotated 180 degrees
-------------------	--

AUTOFEED	Setting of the Carriage Return character: CR disabled ^D = Carriage Return disabled CR enabled = Carriage Return enabled
-----------------	--

CHARS / INCH	Font selection: A = 11 cpi, B = 15 cpi A = 15 cpi, B = 20 cpi ^D A = 20 cpi, B = 15 cpi CPI = Characters Per Inch.
---------------------	--

CODE TABLE	Identifier number of the character code table to use. See paragraph 9.10 to learn about the character tables corresponding to the identification numbers set with this parameter. The character tables set with this parameter are the same set with the command 0x1B 0x74 (refer to the commands manual of the device).
-------------------	--

FONT TYPE	Setting of the font type: International ^D = Enables the use of the 256 characters font tables Chinese GB18030 = Enables the use of the chinese extended font GB18030-2000 When the “International” font is enabled, you need to choose the character code table (parameter “Code Table”). When the Chinese font is enabled, the selection of the character code table is suspended (parameter “Code Table”).
------------------	--

SPEED / QUALITY	Setting of printing speed and printing quality: Normal ^D High Quality High Speed
------------------------	--



PRINT WIDTH

Width of printing area:

48 mm	58 mm	68 mm	78 mm
50 mm	60 mm	70 mm	80 mm
52 mm	62 mm	72 mm	
54 mm	64 mm	74 mm	
56 mm	66 mm	76 mm ^D	

The parameter is printed only with VKP80III emulation enabled. With VKP80II emulation enabled, the printing width is fixed to 76 mm.

PAPER THRESHOLD

Threshold value (in percent) for the recognition of the presence of paper by the paper presence sensor:

30%	70%
40% ^D	80%
50%	90%
60%	

PAPEREND BUFFER CLEAR

Cleaning mode of the data in receive buffer, if the printing is stopped due to lack of paper:

Disabled^D = the data remain in the receive buffer. When the paper runs out, the device keeps the remaining data in the receive buffer and prints the remaining portion of the ticket after that the new paper is loaded.

Enabled = when the paper runs out, all data in the receive buffer are deleted.

**PRINTHEAD TEST
POWERON**

Setting of the performing of the print head test:

Disabled^D = the test is performed only during the printing of the setup report

Enabled = the test is performed at each power on

DATA LOGGER

Setting of the data logger function on the "LOG" folder on the flash memory:

Disabled^D = data logger function disabled

Text = the printed text is stored in .txt file

Graphic = the printed graphic is stored in .bmp file

Text + Graphic = both text and graphic are stored in .txt and .bmp files

The parameter is printed only with VKP80III emulation enabled.

The name of the first text file stored will be "00000001.txt"; the name of the first graphic file stored will be "00000001.bmp"; the file number is incremented automatically, when there is no more space, the oldest files are deleted.

SLEEP TIME [min]

Setting the inactivity period in minutes after which the device enters in sleep mode:

Disabled	10 min
1 min	15 min
2 min	20 min
3 min	25 min
4 min	30 min
5 min ^D	60 min

The parameter is printed only with VKP80III emulation enabled.



LINE SPACE REDUCTION Disable or enable and adjust the reduction of the value of line spacing (vertical distance between the base line of row and the next one). Recommended to reduce paper consumption.

Disabled ^D
25%
50%
75%

This parameter is valid only for VKP80III RX65 LAT and VKP80III RX65 REAR.

LINE FEED REDUCTION Disable or enable and adjust the reduction of the preset distance for paper feed (line feed). Recommended to reduce paper consumption.

Disabled ^D
25%
50%
75%

This parameter is valid only for VKP80III RX65 LAT and VKP80III RX65 REAR.

BARCODE HEIGHT REDUC. Enable, disable and adjust the reduction of the value for the height of the barcode printed. Recommended to reduce paper consumption.

Disabled ^D
25%
50%
75%

This parameter is valid only for VKP80III RX65 LAT and VKP80III RX65 REAR.

PRINT DENSITY Adjusting the printing density:

-50%	-12%	+25%
-37%	0 ^D	+37%
-25%	+12%	+50%

The print quality is strongly influenced by the type of chemical treatment and the type of storage to which the thermal paper has been subjected, as well as by the weight of the same. It may therefore necessary to act on this parameter to obtain the desired print quality.



6.8 Alignment parameters

This printer allows the configuration of the parameters listed in the following table.

The parameters marked with the symbol ^D are the default values.

Settings remain active even after the printer has been turned off and they are stored in non-volatile memory.

BLACK MARK POSITION

Position of the alignment black mark and choice of appropriate black mark sensor:

Disabled ^D = the black mark alignment is not performed

Bottom = the black mark position is detected by the lower mobile sensor (the black mark can be positioned anywhere across the width of the non-thermal side of paper)

Top Side (*) = the black mark position is detected by the upper optional sensor (the black mark is located on the thermal side of paper and near the edge of the paper)

(*) The "Top Side" value is printed only with VKP80III emulation enabled.

BLACK MARK THRESHOLD

Threshold value (in percent) for the recognition of the presence of black mark by the black mark sensor:

30% 70%

40% ^D 80%

50% 90%

60%

If the "Black Mark Position" parameter is disabled, this parameter is not printed.

BLACK MARK DISTANCE

"Black Mark Distance" is the minimum distance (in millimetres) between the upper edge of ticket and the black mark (see [chapter 7](#)).

If the "Black Mark Position" parameter is disabled, the parameters for the "Black Mark Distance" are not printed.

The numeric value of the distance is made up with the following four parameters for the setting of three digits (two for the integer part of the number and one for the decimal part) and of the sign:

Sign setting:

BLACK MARK DISTANCE SIGN

+ ^D = positive distance

- = negative distance

Setting the digit for tens:

BLACK MARK DISTANCE [mm x 10]

0 ^D 2 4 6 8

1 3 5 7 9

Setting the digit for units:

BLACK MARK DISTANCE [mm x 1]

0 ^D 2 4 6 8

1 3 5 7 9



Setting the digit for decimals:

BLACK MARK DISTANCE [mm x 0.1]	0 ^D	2	4	6	8
	1	3	5	7	9

For example, to set the black mark distance to 15 mm, modify the parameters as follows:

Black Mark Distance Sign = +
Black Mark Distance [mm x 10] = 1
Black Mark Distance [mm x 1] = 5
Black Mark Distance [mm x .1] = 0



6.9 Hexadecimal dump

This function is used for the diagnosis of the characters received from the communications port. Characters are printed as hexadecimal code and the corresponding ASCII code (see below). Each line is preceded by a counter in hexadecimal that indicates the number of bytes received.

During the startup, if you hold down the FEED key, the printer enters the self-test routine and print the setup report. The printer remains in standby until a key is pressed or characters are received through the communication port (Hexadecimal Dump mode). For each character sent, the ticket shows the hexadecimal value and the ASCII codes (if the characters are underlined, the receive buffer is full). Shown below is an example of a Hexadecimal Dump:

HEXADECIMAL DUMP									
31	32	33	34	35	...	12345	...		
39	30	31	32	33	...	90123	...		
37	38	39	75	69	...	789ui	...		
68	6B	6A	73	64	...	hkjsd	...		
73	64	66	6B	6A	...	sdfkj	...		
66	73	64	66	6B	...	fsdfk	...		
65	69	6F	79	75	...	eioyu	...		
6F	72	69	75	77	...	oriuw	...		
6F	75	77	65	72	...	ouwer	...		
77	65	72	69	6F	...	werio	...		
72	69	6F	75	77	...	riouw	...		
6B	6C	73	64	66	...	kl sdf	...		
64	66	6B	73	64	...	dfksd	...		
73	64	66	6B	6A	...	sdfkj	...		
66	6B	F2	6A	73	...	fk>j	...		
6A	6B	6C	68			jklh			



7 ALIGNMENT

The device is provided with sensors for the use of alignment black mark in order to handle rolls of tickets with pre-printed fields and a fixed length.

All alignment sensors are “reflection” sensors: this kind of sensor emits a band of light and detects the quantity of light reflected to it. The presence of the black mark is therefore detected by the amount of light that returns to the sensor, considering that the light is reflected by the white paper and absorbed by the black mark.

The following paragraphs show how to correctly set the configuration parameters of device in order to assure the alignment.

7.1 Enable alignment

Device is provided with two sensors for alignment, placed as follows:

- one mobile sensor facing the non-thermal side of paper
- one fixed sensor (optional) facing the thermal side of paper.

To guarantee the alignment, it is necessary to correctly choose the sensor to use for the black mark detection depending on the location of the black mark on ticket.

To do this, you must enable the parameter “Black Mark Position” during the setup procedure (see [chapter 6](#)) and set the correct value of this parameter as described in the following table.

SENSOR USED (see following figures)	VALUE OF THE “BLACK MARK POSITION” PARAMETER	USING MODE OF SENSORS	BLACK MARK TYPE
-	Disabled	-	Alignment disabled
1	Bottom	Reflection	Black mark printed on the non-thermal side of paper
2	Top Side *	Reflection	Black mark printed on the thermal side of paper

* only for models with upper black mark sensor and with VKP80III emulation enabled.

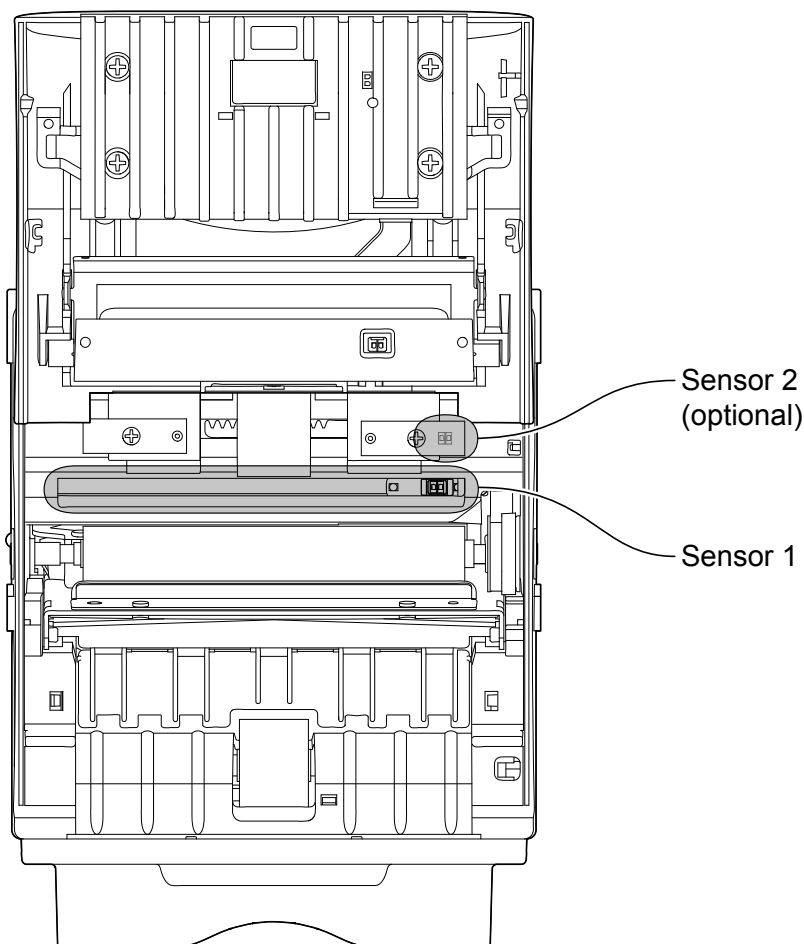



The following figures show the usable format of paper and the corresponding sensors used for alignment:

Paper with black mark on the non-thermal side

In standard model, the detection of black mark is performed on the non-thermal side of paper by the mobile sensor.

Paper with black mark on the thermal side

In model with optional sensor, the detection of black mark is performed on the thermal side of paper by the fixed sensor.

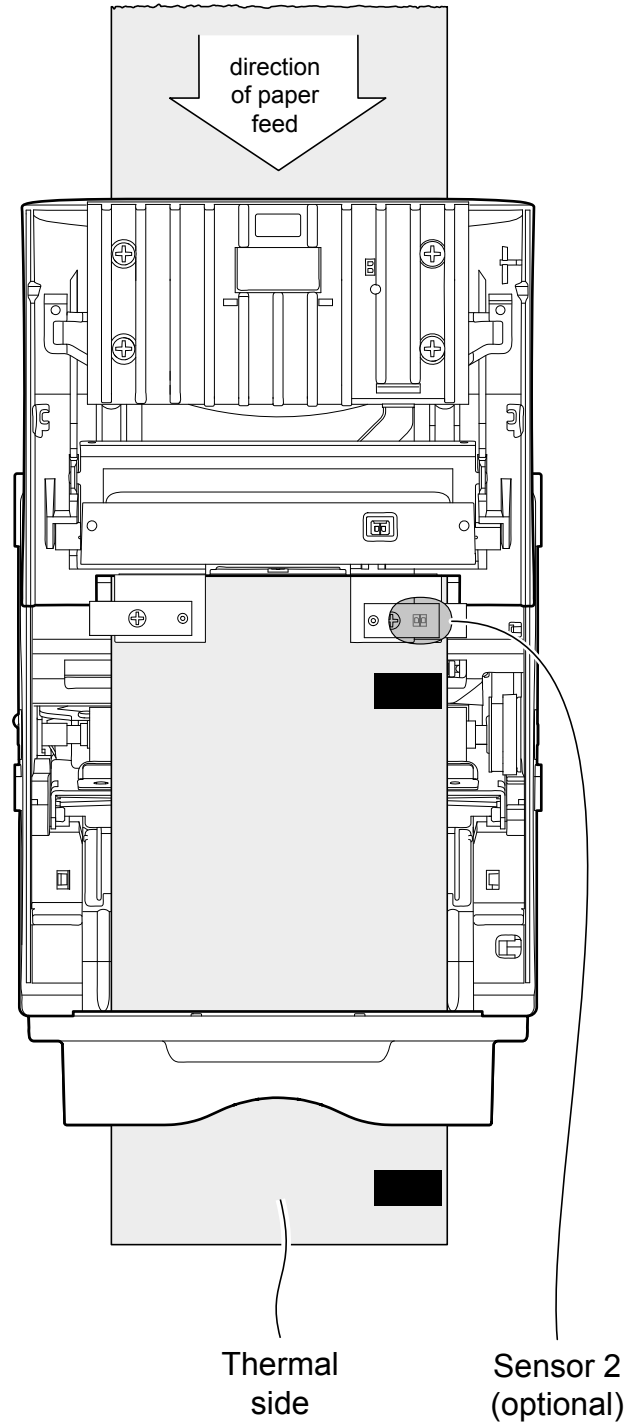
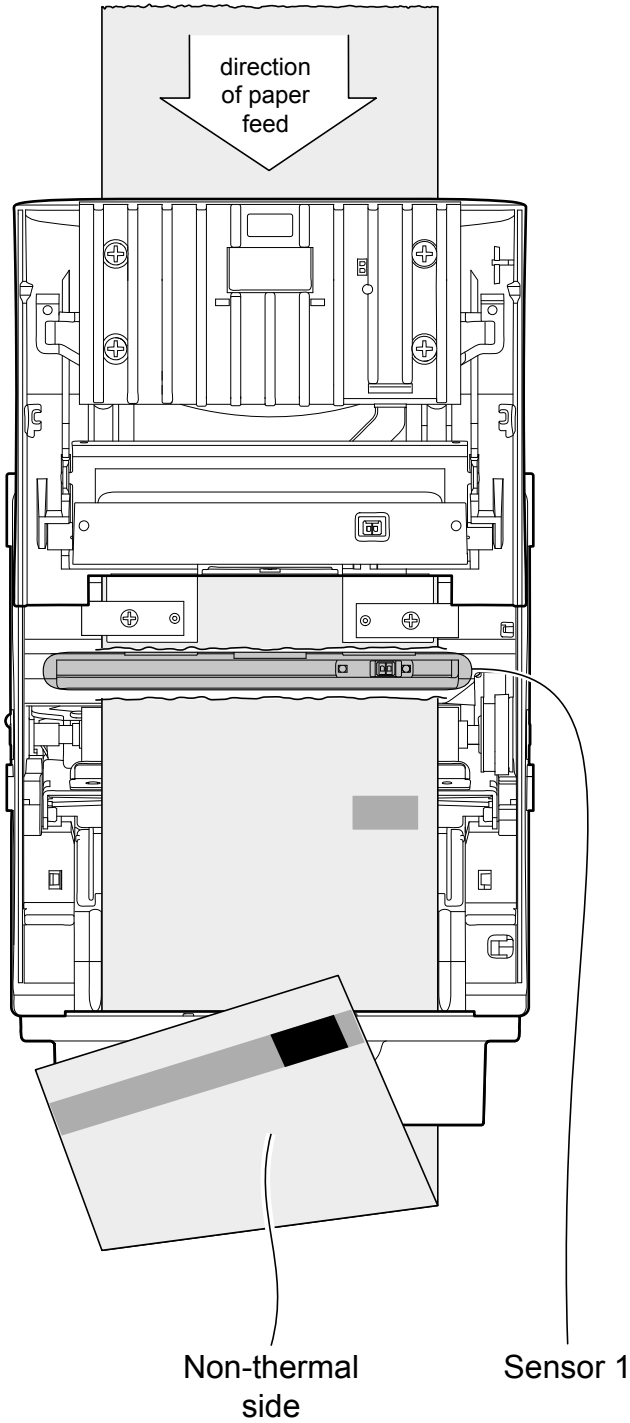

7.2 Calibration

The sensor calibration occurs automatically and consists in adjusting the quantity of light emitted to match the degree of whiteness of the paper used and the degree of black of the mark printed on paper.

The device automatically performs the self-calibration during the Setup procedure only if the “Black Mark Position” parameter is set to a value other than “Disabled” (see [chapter 6](#)).

When self-calibration starts, the device performs some paper feeds and then it prints the calibration result and the value of the PWM duty-cycle (also expressed as a percentage) of the alignment sensor driver so that it can be perform an optimal black mark detection:

```
Autosetting Black Mark : OK
PWM Duty Cycle : 2.7 V [82%]
```

The “Autosetting Black Mark” parameter indicates the result of the self-calibration procedure; OK will appear if it has been successful, NOT OK will appear if the procedure has failed.

After the printing of the procedure result, the device offers the execution of the function of paper characterization “Characterize Paper” and the change of the “Black Mark Threshold” parameter which represents the detection threshold of the black mark.

Choosing the “Yes” value for the “Characterize Paper” parameter, the device prints a graphic representation (see following figures) of the outgoing voltage of the alignment sensor (expressed as a percentage) and the “Black Mark Threshold” value. This graphic representation is useful to set the most suitable value to assign to the “Black Mark Threshold” parameter and then to better identify the optimal threshold value which takes into account the variations of the signal and the small oscillations around zero.

The following figure shows an example of paper with the non-thermal paper printed with black marks: the outgoing voltage is constant while passing the white paper between two black marks and presents a peak at each black mark. In this case, the optimal value for the “Black Mark Threshold” parameter is placed about half of the peak.

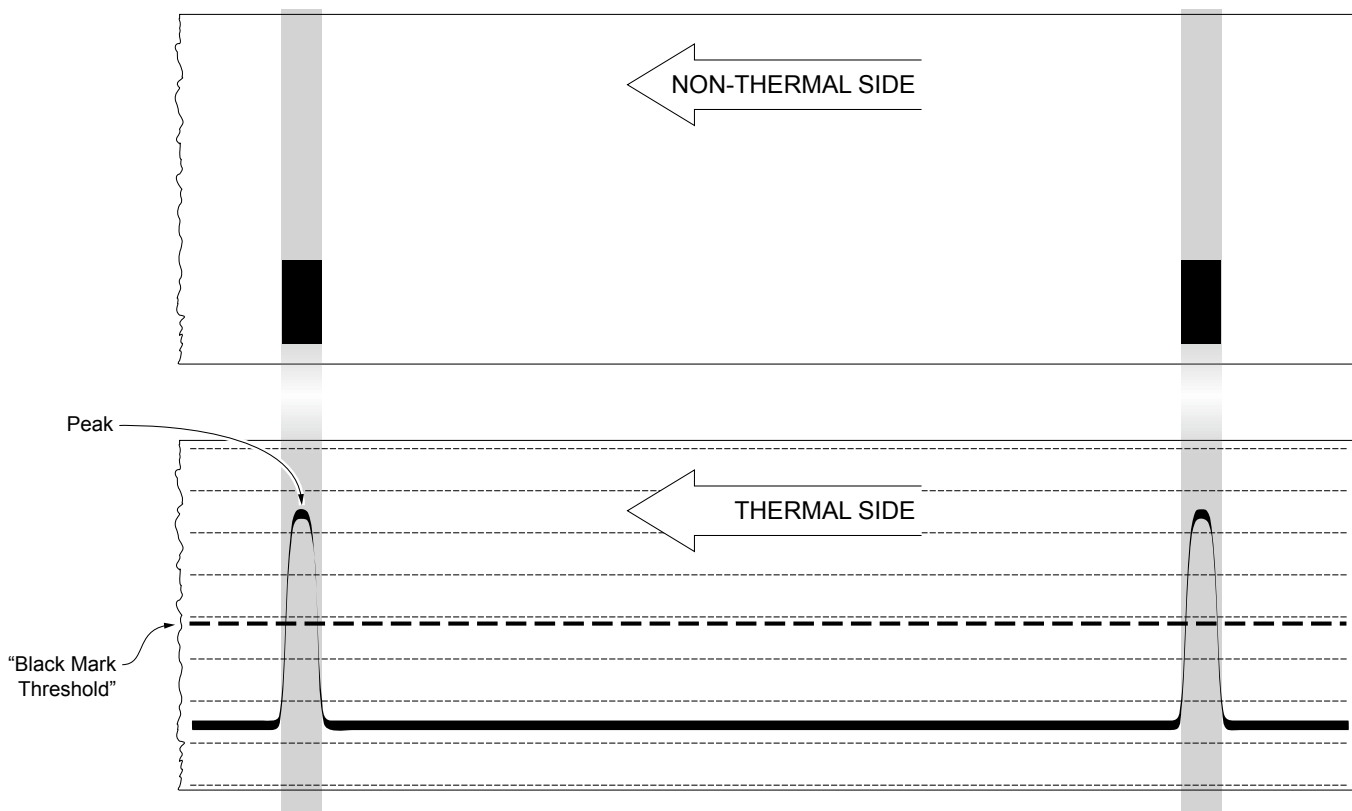

The following figure shows an example of paper with the non-thermal paper printed with black marks and other graphics (for example, a barcode): the outgoing voltage is constant while passing the white paper between two black marks, presents a peak at each black mark and presents some “noise” at each barcode. In this case, the optimal value for the “Black Mark Threshold” parameter is located about halfway between the peak value and the maximum value of the “noise”.

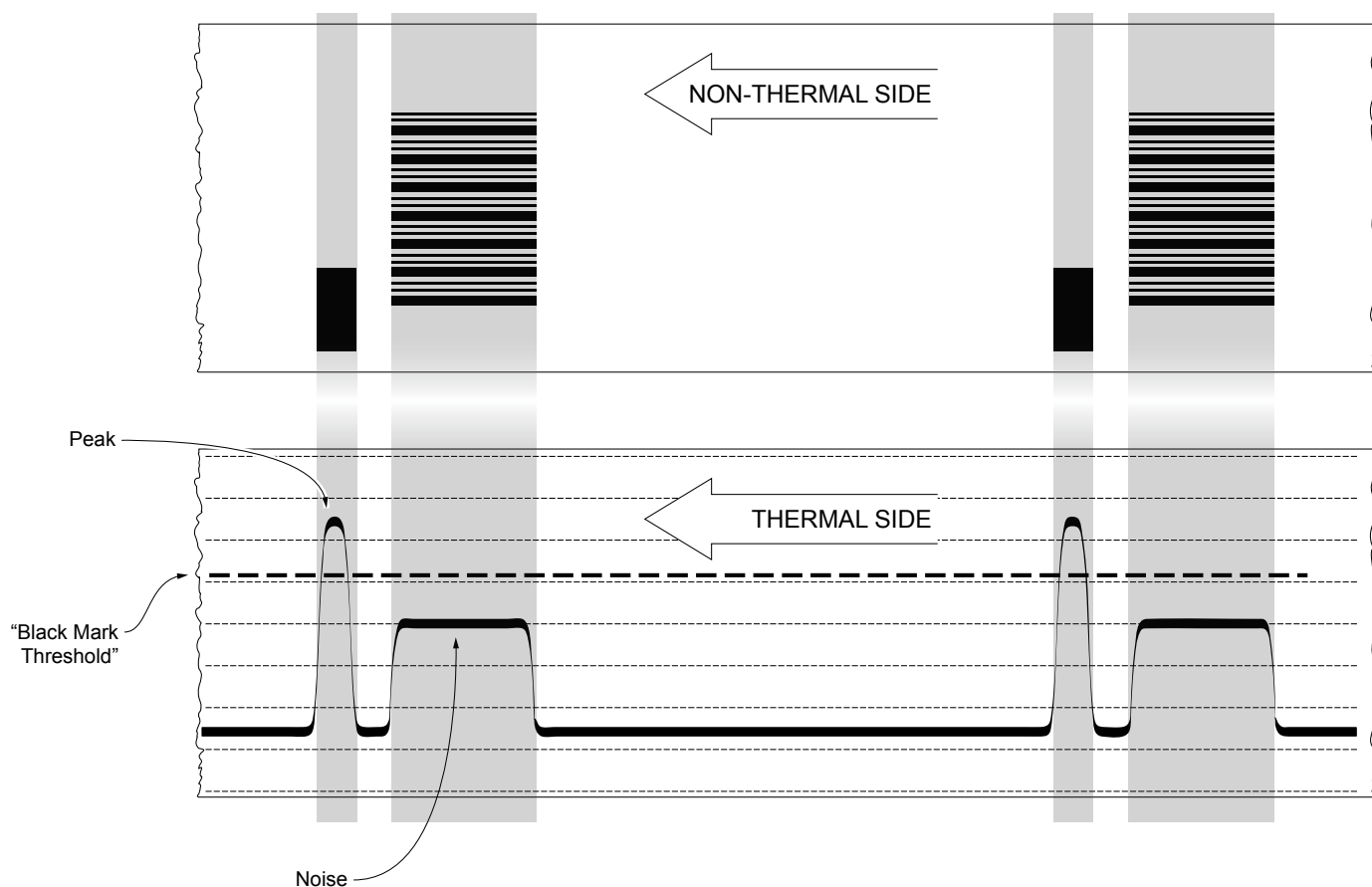

If the maximum value of “noise” read by the sensor is very close to the peak value, it might be difficult to place the value of the “Black Mark Threshold” at an intermediate point. In these cases, it is mandatory that the portion of paper between the point of printing end and the front black mark is completely white (no graphics). In this way, the only next graphic detected by the sensor for alignment after the printing end will be the black mark.

7.3 Alignment parameters

The “alignment point” is defined as the position inside the ticket to use for the black mark alignment. The distance between the black mark edge and the alignment point is defined as “Black Mark Distance”.

Referring to the front of the black mark, the value of “Black Mark Distance” varies according to emulation set:

- VKP80III emulation: “Black Mark Distance” value varies from -5 mm minimum and 99.9 mm maximum
- VKP80II emulation: “Black Mark Distance” value varies from 0 mm minimum and 32 mm maximum.

If the “Black Mark Distance” value is set to 0, the alignment point is set at the beginning of the black mark.

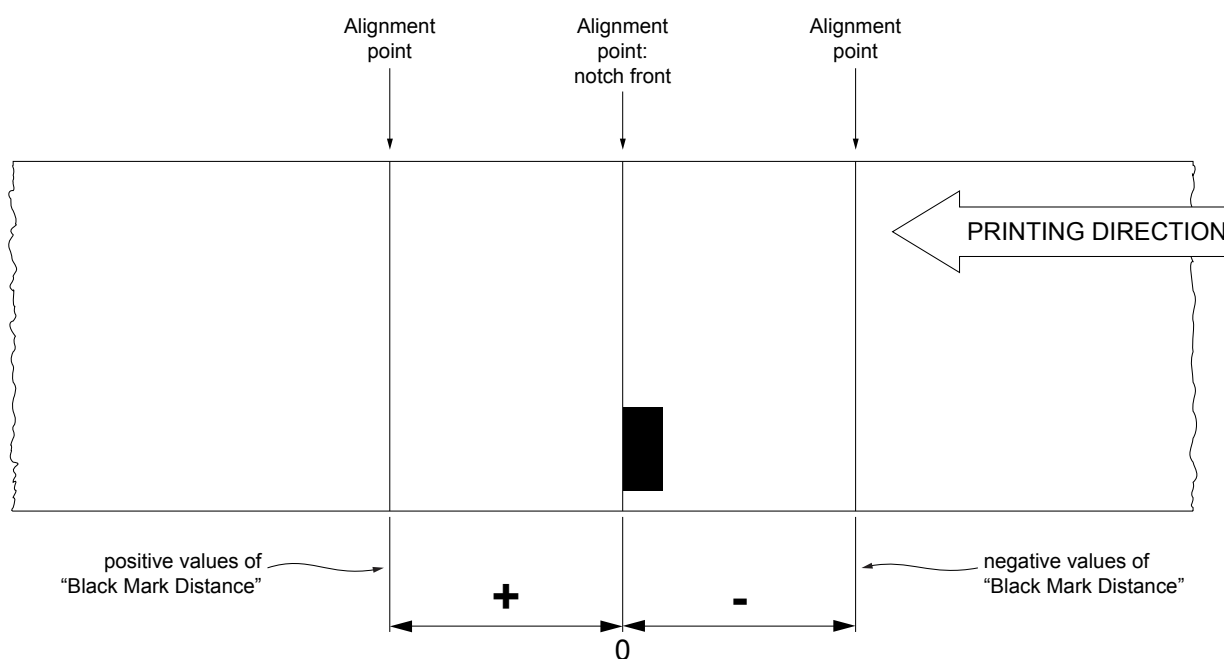



The following figure shows an example of paper with alignment point set by a positive value of “Black Mark Distance” (“Black Mark Distance” = + A):

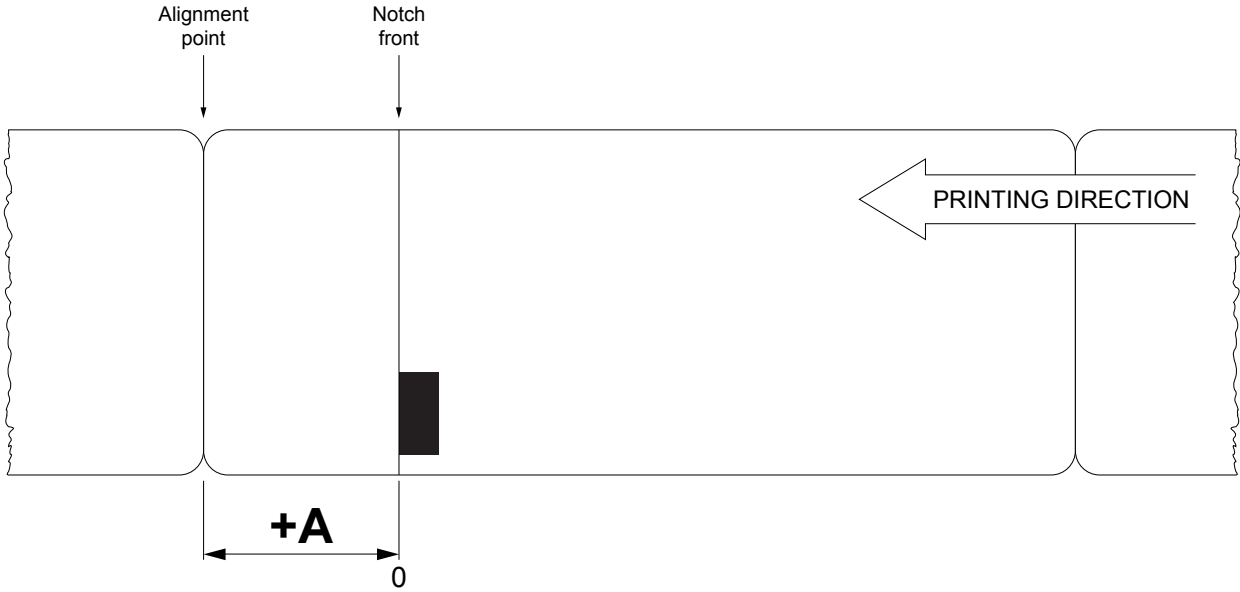

To set a negative value of the “Black Mark Distance” parameter is useful in cases where the alignment point refers to the black mark printed on the previous ticket. In the following images, the value of “Black Mark Distance” parameter is set to -A.

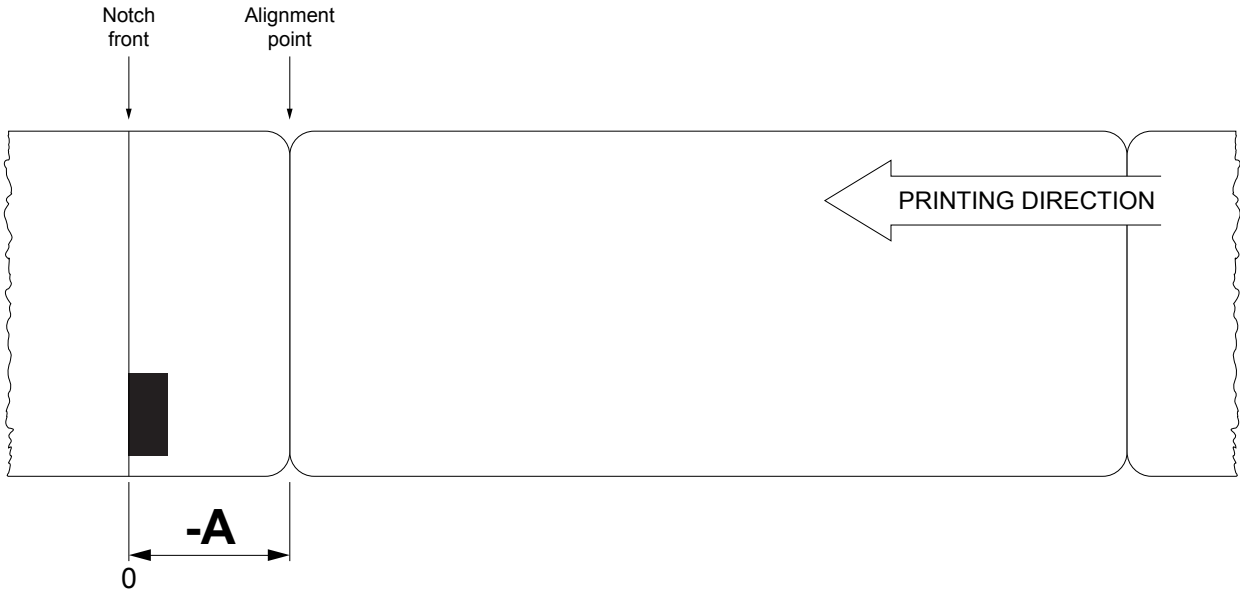

The following figure shows a section of the device with the paper path and the distances between the alignment sensors, the printing head and the autocutter (cutting line), where:

A = 11.9 mm = distance between the cutting line and the printing line on paper.

B = 15.3 mm = distance between the the printing line and the mobile alignment sensors (bottom).

C = 11.8 mm = distance between the mobile alignment sensor (bottom) and the upper alignment sensor (optional).

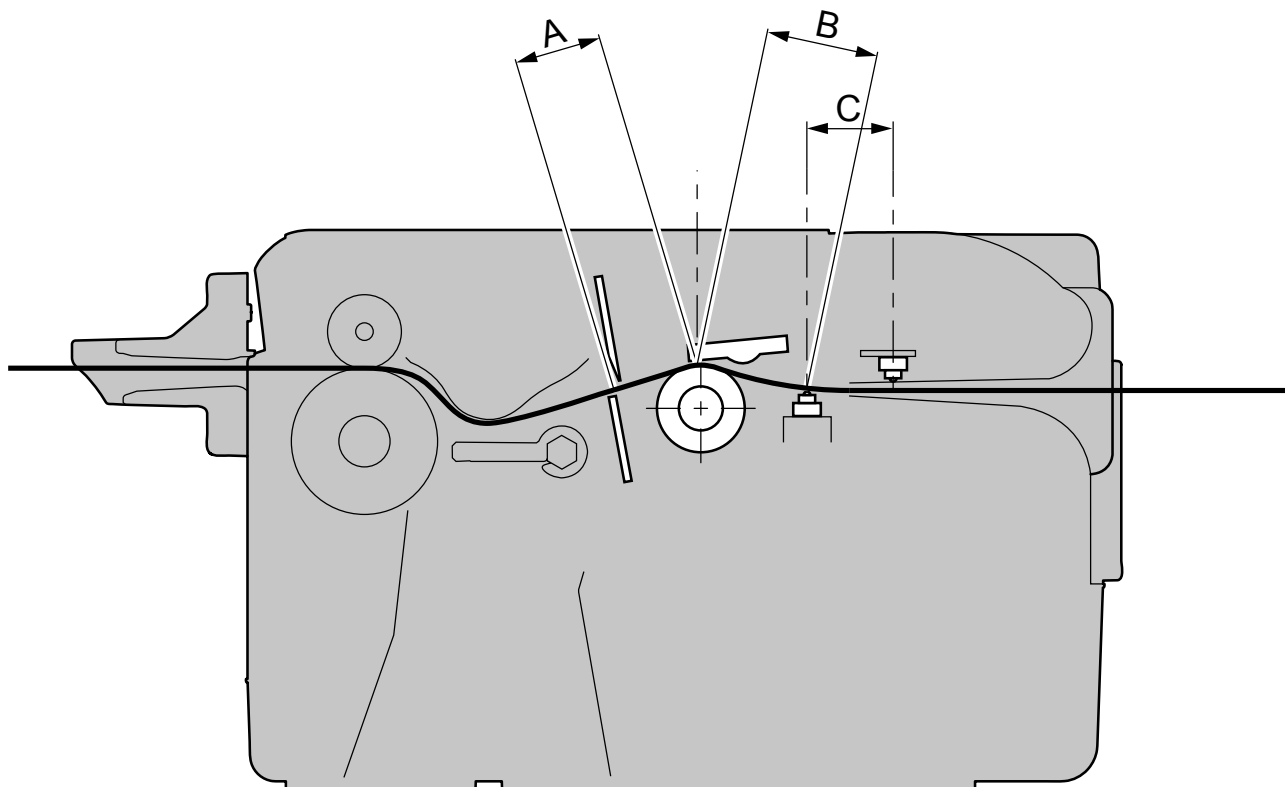

VKP80II, VKP80III emulation

To define the alignment point you need to set the device parameters that compose the numerical value of the “Black Mark Distance” parameter (see [paragraph 6.8](#)).

For example, to set a black mark distance of 15 mm between the black mark and the alignment point, the parameters must be set on the following values:

Black Mark Distance Sign	:	+
Black Mark Distance [mm x 10]	:	1
Black Mark Distance [mm x 1]	:	5
Black Mark Distance [mm x 0.1]	:	0

The “Black Mark Distance” parameter, may be modified as follows:

- during the setup procedure of the device (see [chapter 6](#)).
- by using the 0x1D 0xE7 command (for more details, refer to the commands manual).
- by driver.

7.4 Printing area

In order to print ticket containing only one black mark and to not overlay printing to a black mark (that will make it useless for the next alignment), it is important to well calibrate:

- the length of the printing area of ticket according to the inter-black mark distance;
- the value for the paper recovery after a cut (if present)

The following figure shows an example of tickets with “Black Mark Distance” set to 0:

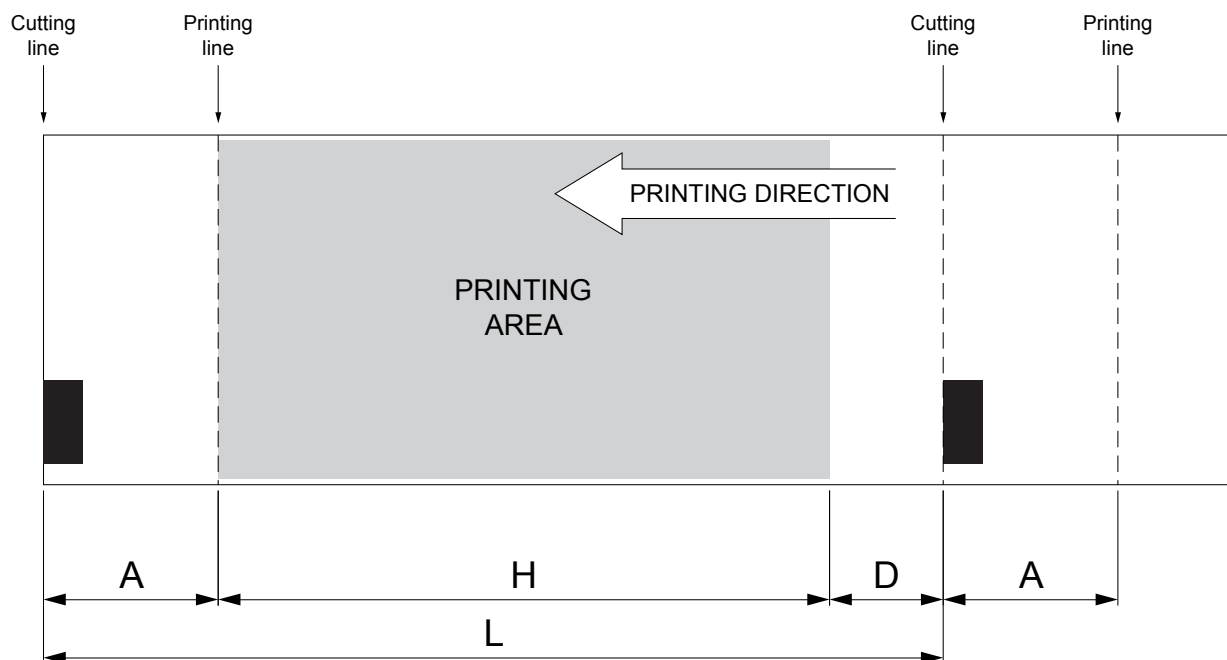

A “Non-printable area” generated from:

“Distance between cutter/printing head” - “Value for the paper recovery after a cut”

where:

“Distance between autocutter/printing head” = 11.9 mm (fixed distance)

“Value for the paper recovery after a cut” in VKP80II emulation= 0 mm,

“Value for the paper recovery after a cut” in VKP80III emulation = variable from 0 mm (default value) to 11.9 mm according to the settings of 0x1C 0xC1 command (see commands manual)

H Distance between the first and the last print line, called “Height of the printing area”.

L Distance between an edge of the black mark and the next one, called “Inter-black mark distance”.

D Automatic feed for alignment at the next black mark.

To use all the black marks on the paper, you must comply with the following equation:

$$H + A \leq L$$

The height of the printing area H can be increased to make no progress on alignment D but no further.





8 MAINTENANCE

8.1 Planning of cleaning operations

The regular cleaning of the device keeps the print quality and extends its life. The following table shows the recommended planning for the cleaning operations. If you use the device in dusty environments, you must reduce the intervals between the cleaning operations.

For specific procedures, see the following pages.

EVERY PAPER CHANGE	
Printing head	Use isopropyl alcohol
Rollers	Use isopropyl alcohol
EVERY 5 PAPER CHANGES	
Autocutter	Use compressed air
Autocutter compartment	Use compressed air or tweezers
Paper path	Use compressed air or tweezers
Sensors	Use compressed air
EVERY 6 MONTHS OR AS NEEDED	
Case	Use compressed air or a soft cloth



8.2 Cleaning

For periodic cleaning of the device, see the instructions below

Sensors

1

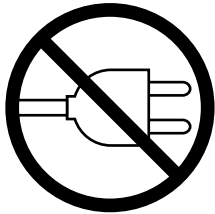



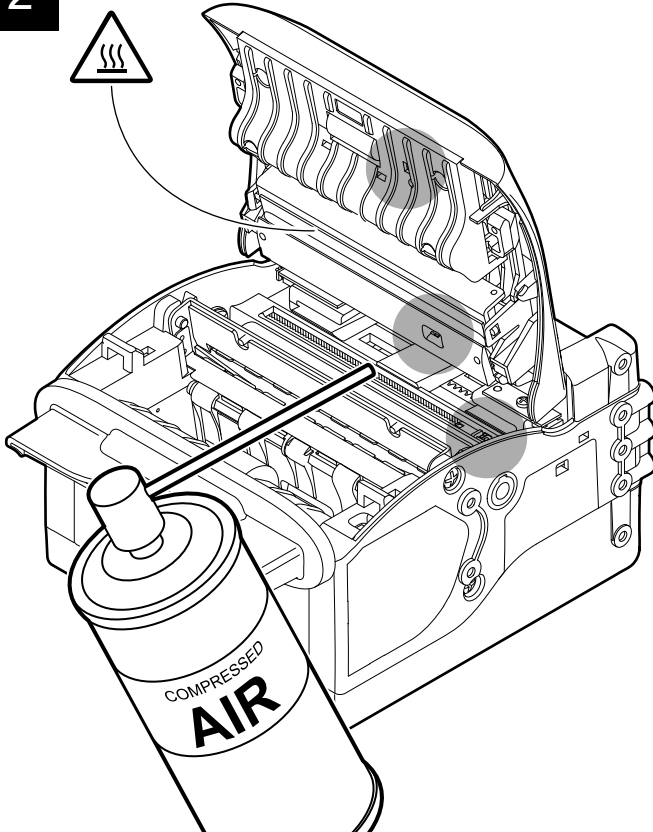

Disconnect the power supply cable and open the device cover (see [paragraph 5.1](#)).

2

ATTENTION:
Do not use alcohol, solvents, or hard brushes.
Do not let water or other liquids get inside the machine.

Clean the device sensors by using compressed air.

Paper path

1



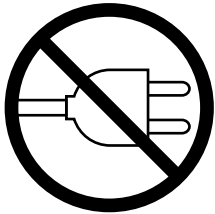

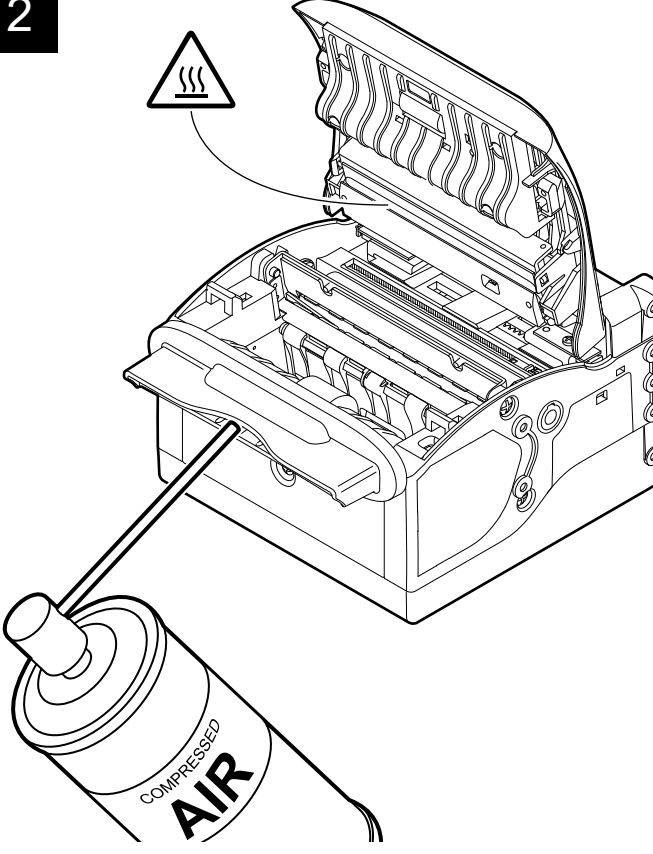

Disconnect the power supply cable and open the device cover (see [paragraph 5.1](#)).

2

ATTENTION:
Do not use alcohol, solvents, or hard brushes.
Do not let water or other liquids get inside the machine.

Clean the area involved in the passage of paper by using compressed air.

Printing head

1

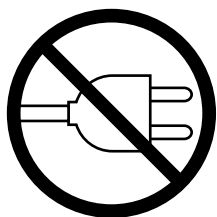

Disconnect the power supply cable and open the device cover (see [paragraph 5.1](#)).

2

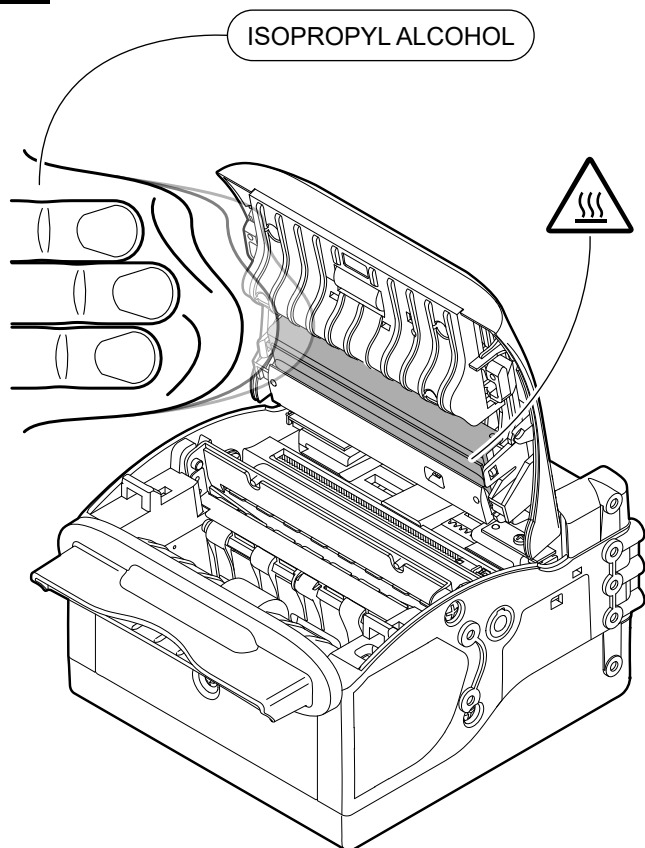

ATTENTION:
Do not use solvents, or hard brushes.
Do not let water or other liquids get inside the machine.



Clean the printing head by using a non-abrasive cloth moistened with isopropyl.

Platen rollers

1

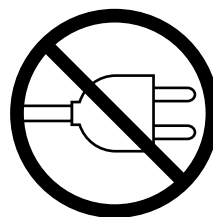

Disconnect the power supply cable and open the device cover (see [paragraph 5.1](#)).

2

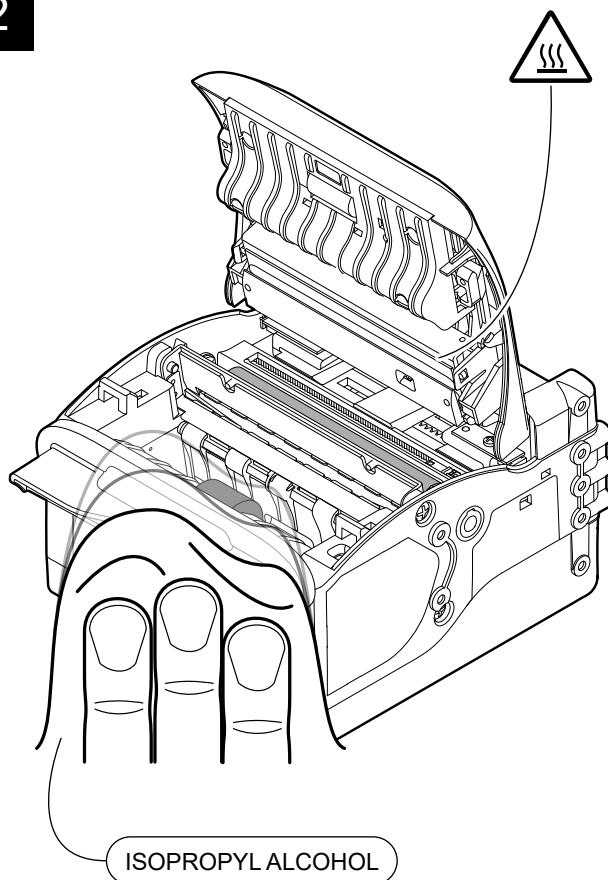

ATTENTION:
Do not use solvents, or hard brushes.
Do not let water or other liquids get inside the machine.



Clean the dragging roller and the ejector roller by using a non-abrasive cloth moistened with isopropyl.

Case

1

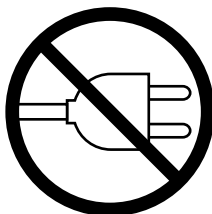

Disconnect the power supply cable.

2

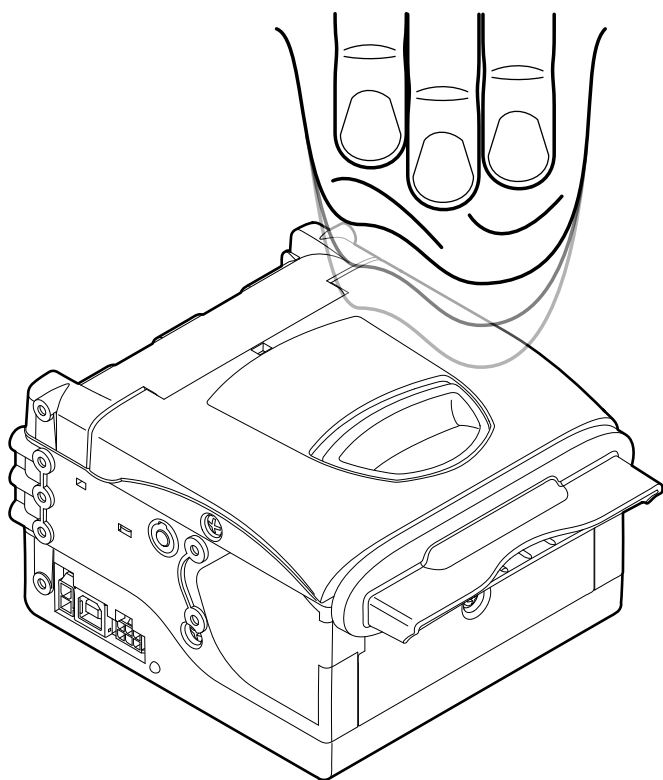

ATTENTION:

Do not use alcohol, solvents, or hard brushes.
Do not let water or other liquids get inside the machine.

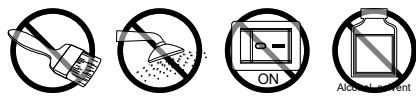

To clean the device,
use compressed air or a soft cloth.

Autocutter

1

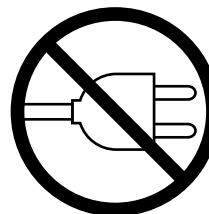

Disconnect the power supply cable and
open the device cover (see [paragraph 5.1](#)).

2

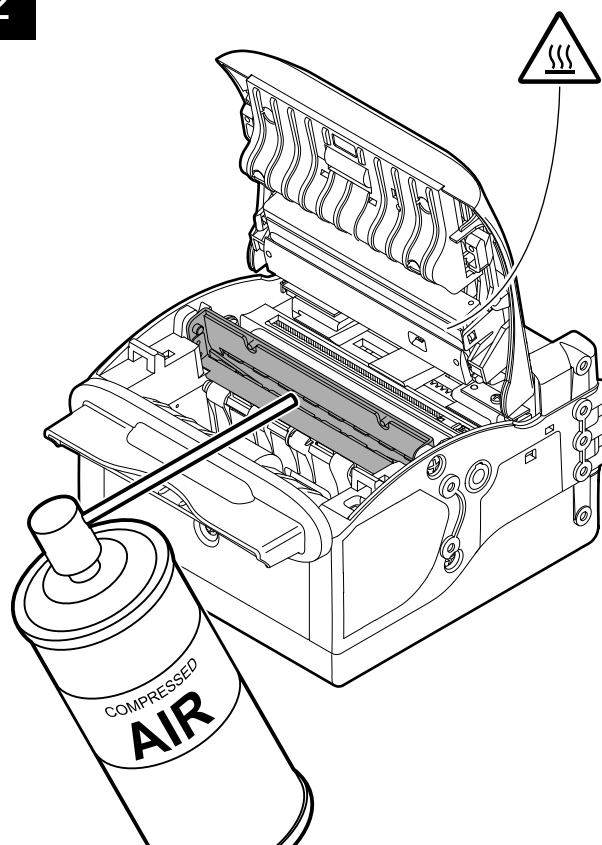

ATTENTION:

Do not use alcohol, solvents, or hard brushes.
Do not let water or other liquids get inside the machine.

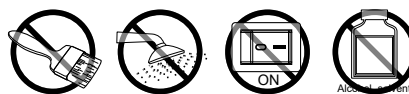

Clean the autocutter by
using compressed air.

Autocutter compartment

1

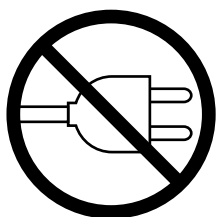

Disconnect the power supply.

2

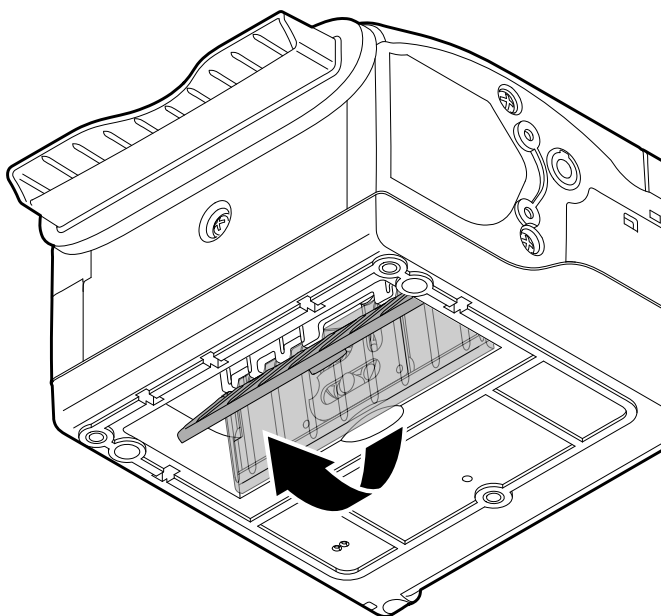

Lift the magnetic bulkhead that closes the autocutter compartment.

3

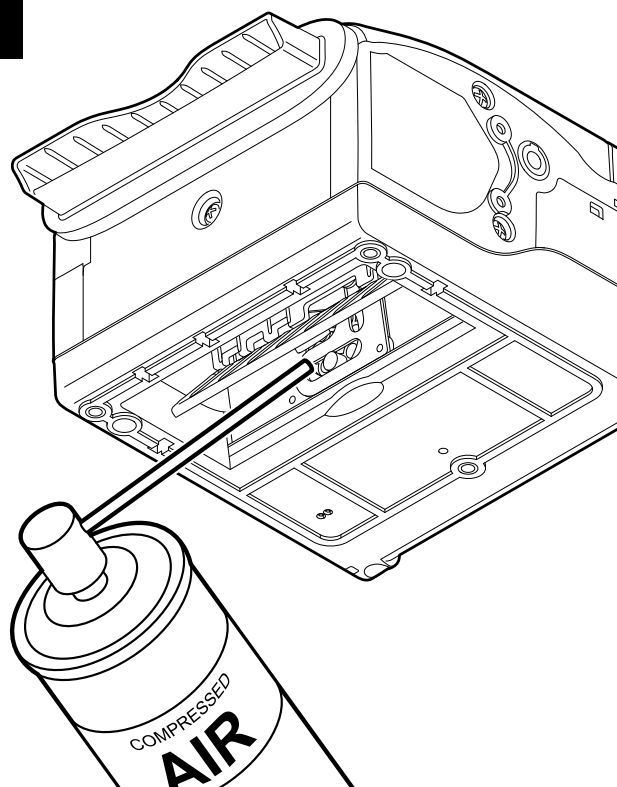

ATTENTION:

Do not use alcohol, solvents, or hard brushes.

Do not let water or other liquids get inside the machine.

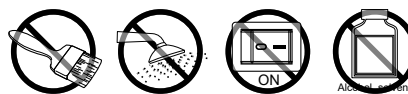

Remove any scraps of paper and the accumulated paper dust from the autocutter compartment.

4

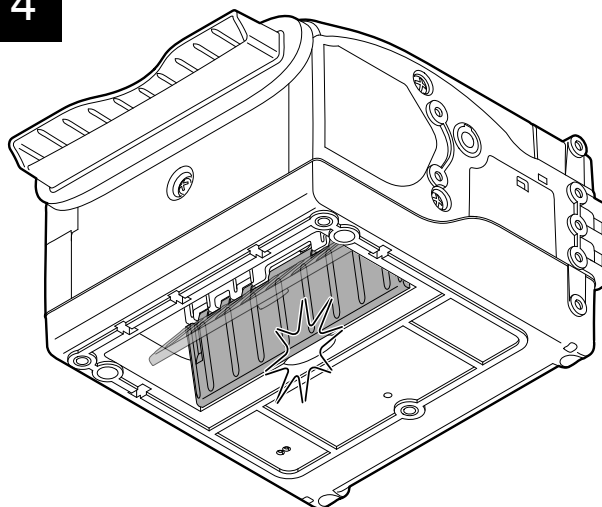

Lower the bulkhead to close the autocutter compartment.

8.3 Firmware upgrade

Firmware upgrade can be performed by using the “PrinterSet” software tool available on www.custom4u.it. To upgrade firmware, proceed as follows:

1



Login to the website www.custom4u.it, type in the product code of the device and download the latest firmware release available.

2

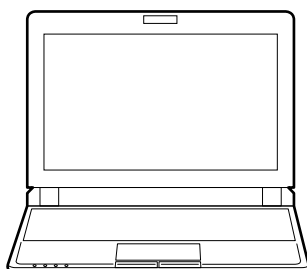

Connect the device to a PC directly (see [paragraph 4.2](#)), without using HUB devices.

3

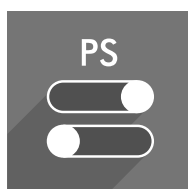

Start the “PrinterSet” software tool.

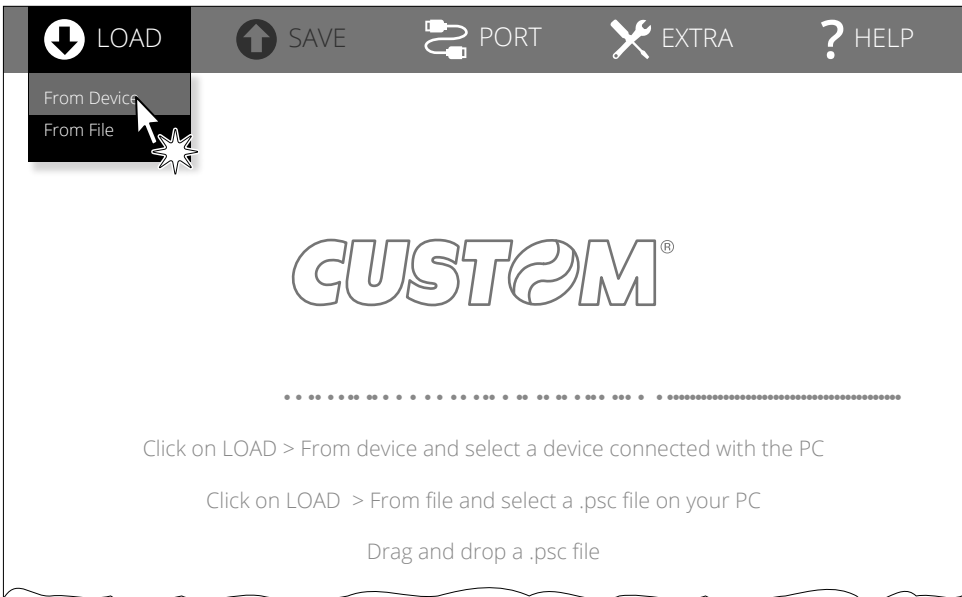

Click on LOAD > FROM DEVICE and select the device connected to the PC.



Click on UPGRADE and follow the instructions shown on the screen.

ATTENTION:
During saving, it is strongly discouraged to disconnect the communication cable or to remove the power supply of the PC or the device.





9 SPECIFICATION

9.1 Hardware specifications

GENERAL	
Sensors	Paper presence in input, ticket paper presence in output, head temperature, ejector position, mobile detector for black mark on the non-thermal side of paper, fixed detector for black mark on the thermal side of paper (optional), printing unit open, tilting bulkhead position, low paper on external paper roll holder (optional)
Emulations	VKP80II VKP80III
Printing driver	Windows XP Windows VISTA (32/64 bit) Windows 7 (32/64 bit) Windows 8 (32/64 bit) Windows 8.1 (32/64 bit) Windows 10 (32/64 bit) Windows 11 (64 bit) OPOS Linux (32/64 bit) Android iOS
INTERFACES	
RS232 serial port (only for VKP80III RX65 LAT, VKP80III RX65 REAR)	from 1200 bps to 115 200 bps
USB port	12 Mbit/s (USB 2.0 full speed)
Ethernet port (only for VKP80III ETH)	10 Mbit/s, 100 Mbit/s
MEMORIES	
Receive buffer	16 kB
Flash memory	1 MB internal + 4 MB external (of which 1 MB available)
RAM memory	128 kB internal + 8 MB external



PRINTER

Resolution	203 dpi (8 dots/mm)
Printing method	Thermal, fixed head
Head life ⁽¹⁾	
Abrasion resistance ⁽²⁾	100 km (with recommended paper, 12.5% duty cycle)
Pulse durability	100 M (referred to each dot)
Printing width	from 48 mm to 80 mm (2 mm step)
Printing mode	normal, 90°, 180°, 270°
Printing format	Height/width from 1 to 8, bold, reverse, underlined, italic
Character fonts	
VKP80II emulation	45 character code tables (see paragraph 9.10) Extended chinese GB18030-2000
VKP80III emulation ⁽³⁾	45 character code tables (see paragraph 9.10) Extended chinese GB18030-2000 2 TrueType font
Printable barcode	UPC-A, UPC-E, EAN13, EAN8, CODE39, ITF, CODABAR, CODE93, CODE128, CODE32, PDF417, DATAMATRIX, AZTEC, QRCODE
Printing speed ^{(1) (4)}	High Quality = 100 mm/s Normal = 150 mm/s High Speed = 200 mm/s

PAPER

Type of paper	Thermal rolls, heat-sensitive side on outside of roll
Paper width	
Without paper roll holder support	from 50 mm to 82.5 mm
With paper roll holder support (optional, see chapter 11)	from 60 mm to 82.5 mm
With shutter device (optional, see chapter 11)	from 60 mm to 82.5 mm



Paper weight	from 55 g/m ² to 110 g/m ²
Recommended types of paper	APPVION Alpha Plus 600 KANZAKI Lotto 500 KANZAN KLS-46 MITSUBISHI PF5067 and TL3000
Minimum ticket length	70 mm (using the command 0x1D 0xE8 it can be decreased up to 54 mm)
Paper end	Not attached to roll core
External roll diameter ⁽⁵⁾	max. 150 mm
External roll core diameter	25 mm
Core type	Cardboard or plastic
AUTOCUTTER	
Paper cut	Total cut
Estimated life ⁽¹⁾	1000000 cuts (with paper thickness 100 µm, ambient temperature)
DEVICE ELECTRICAL SPECIFICATIONS	
Power supply	24 Vdc ±10% (optional external power supply)
Typical consumption ⁽⁴⁾	1 A
Medium consumption ⁽⁶⁾	1.5 A
Standby consumption	
VKP80III RX65 LAT VKP80III RX65 REAR	0.04 A
VKP80III ETH	0.08 A
POWER SUPPLY ELECTRICAL SPECIFICATIONS code 963GE020000071 (optional)	
Power supply voltage	from 90 Vac to 264 Vac
Frequency	from 47 Hz to 63 Hz
Output	24 V, 2.5 A
Power	60 W



ENVIRONMENTAL CONDITIONS

Operating temperature	from -20 °C to +70 °C ⁽⁷⁾
Relative humidity (RH)	from 10% to 80% (without condensation)
Storage temperature	from -20 °C to +70 °C
Storage relative humidity (RH)	from 10% to 90% (without condensation)

NOTES:

- (1) : Respecting the regular schedule of cleaning for the device components.
- (2) : Damages caused by scratches, ESD and electromigration are excluded.
- (3) : "Veramono.ttf" and "Vera.ttf" are installed on device.
- (4) : Referred to a standard CUSTOM receipt (L = 10 cm, density = 12.5% dots on).
- (5) : For external rolls diameter higher to Ø120 mm it's recommended to use a paper pretensioning device.
- (6) : Referred to the UL measurements (Speed/Quality = High Speed, Print density = +50%, Ticket = 12.5% dots on).
- (7) : If you use the device with the power supply code 963GE020000071, supplied as an accessory, the operating temperature range is from 0 °C to +40 °C.



9.2 Character specifications

Character set	3		
Character density	11 cpi	15 cpi	20 cpi
Number of columns	33	43	60
Chars / s	2251	2895	4053
Lines / s	66	66	66
Characters (L x H mm)-Normal	2.25 x 3	1.75 x 3	1.25 x 3

NOTA: Theoretical values.

9.3 Ejector specifications

	Ticket length	Ticket presentation
"Retracting" function	70 mm	10 mm
	80 mm	10 mm - 60 mm ⁽¹⁾
	80 mm - 220 mm	10 mm - 60 mm ⁽¹⁾
	Ticket length	Ticket presentation
"Ejecting" function	70 mm	10 mm
	> 80 mm	10 mm - 60 mm ⁽¹⁾
	350 mm ⁽²⁾	10 mm - 60 mm ⁽¹⁾

NOTES:

(1) : Maximum length of the ticket's part presented recommended to guarantee the device efficiency.

(2) : Maximum ticket length recommended to guarantee the device efficiency.



9.4 Device dimensions

Length	143.5 mm
Height	76.4 mm (with cover closed) 157.4 mm (with cover open)
Width	116 mm
Weight	800 g

All the dimensions shown in following figures are in millimetres.

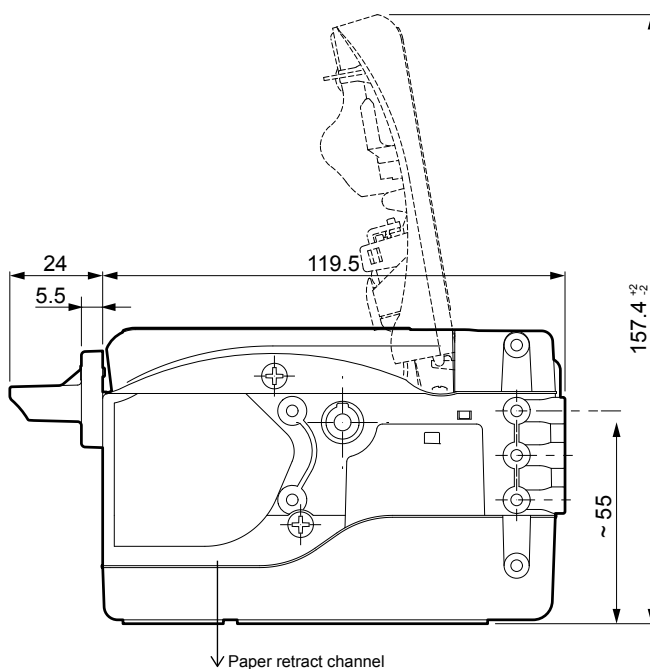
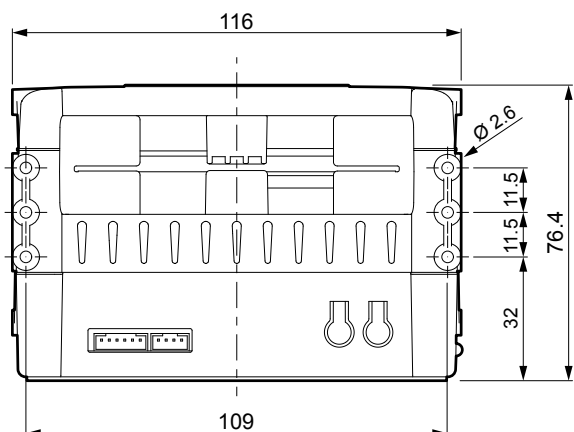
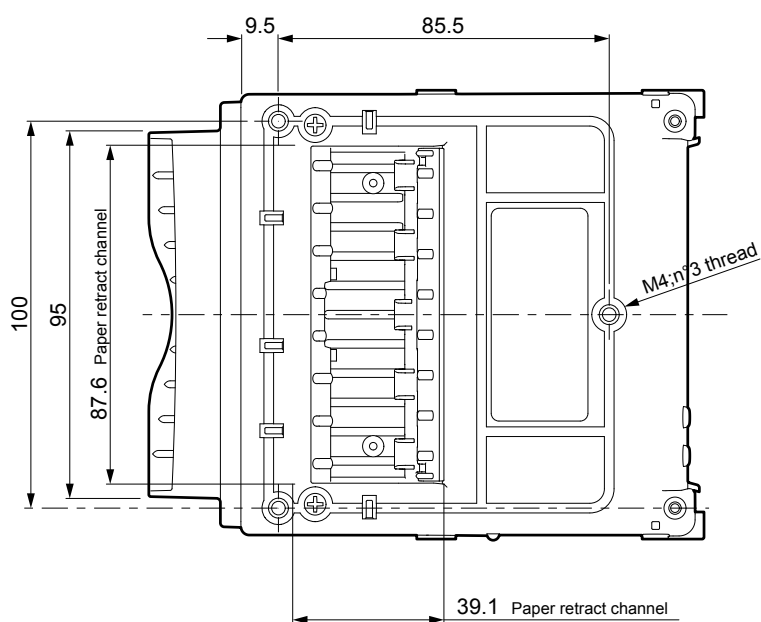



9.5 Device dimensions with shutter device code 976DX01000008 (optional)

Length	157.5 mm
Height	76.4 mm (with cover closed) 157.4 mm (with cover open)
Width	116 mm
Weight	850 g

All the dimensions shown in following figures are in millimetres.

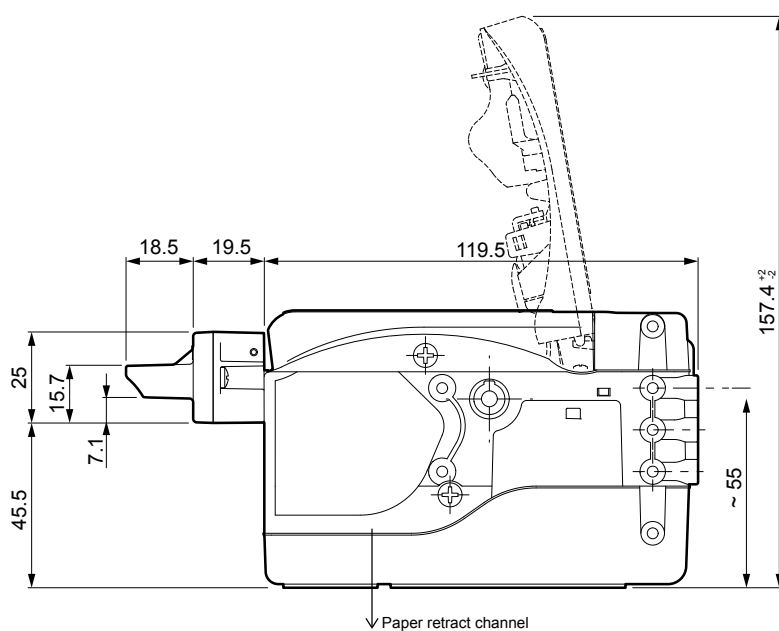
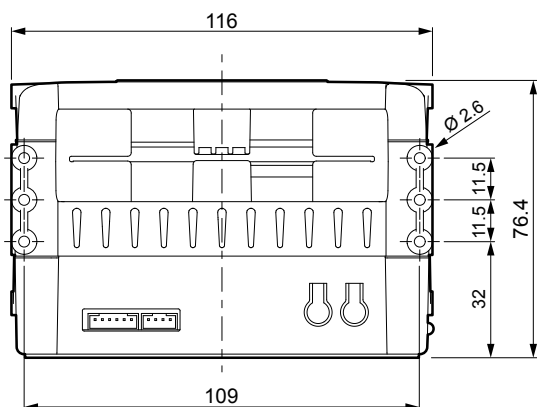
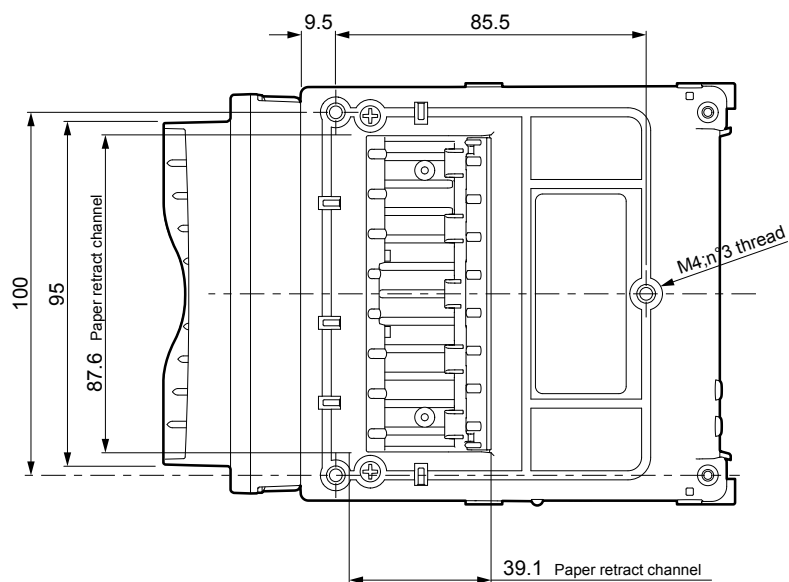

9.6 Device dimensions with adjustable paper roll holder code 974DX01000001 (optional)

All the dimensions shown in following figures are in millimetres.

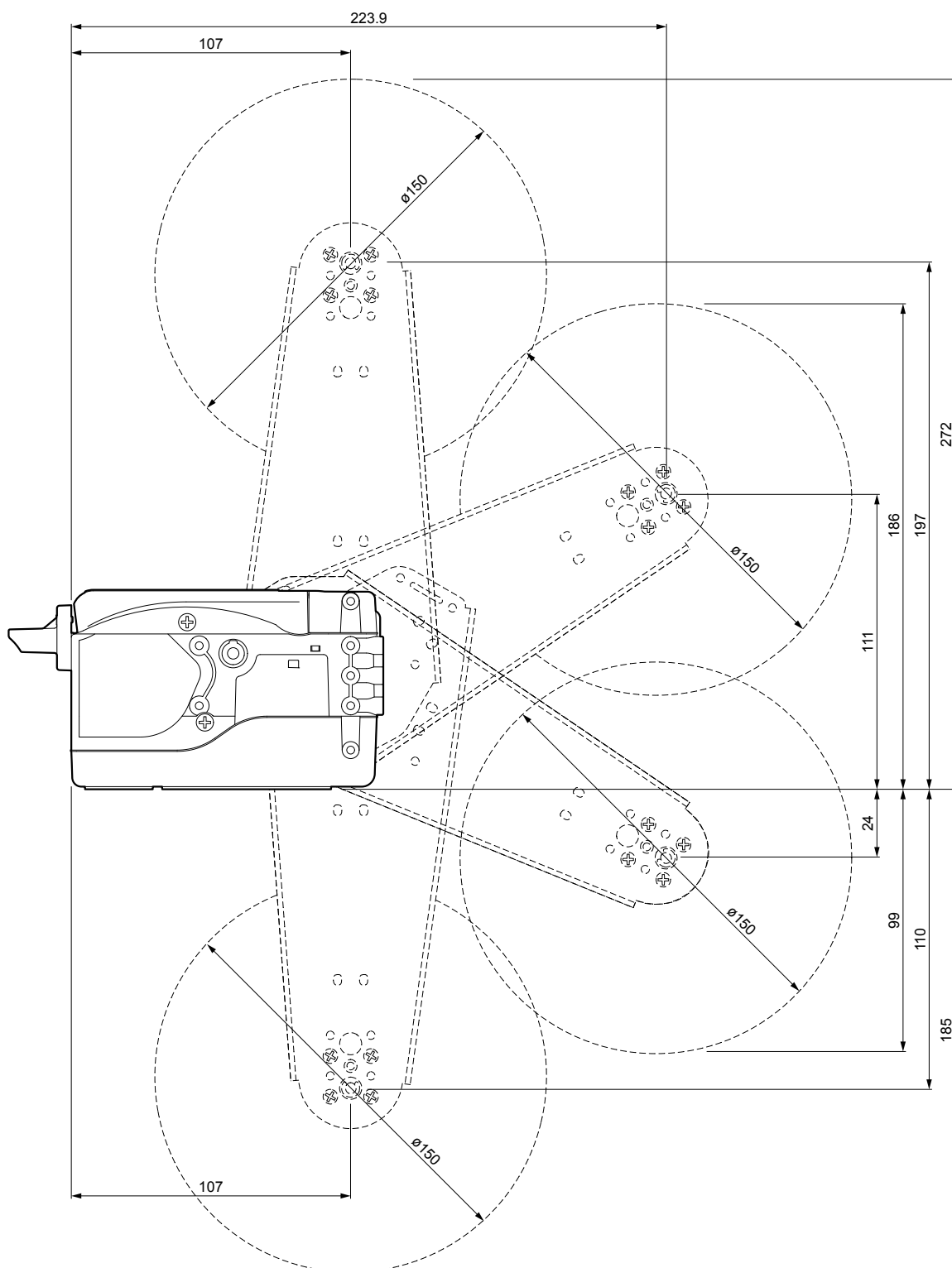



Check the compatibility of the mounting position with the device model:

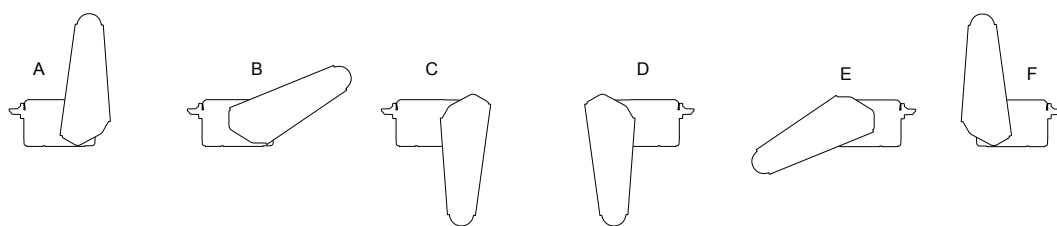

VKP80III RX65 LAT	•	•	•			
VKP80III RX65 REAR	•	•	•	•	•	•
VKP80III ETH	•	•	•			



9.7 Device dimensions with adjustable paper roll holder with inverted paper roll pin code 974DX01000001 (optional)

All the dimensions shown in following figures are in millimetres.

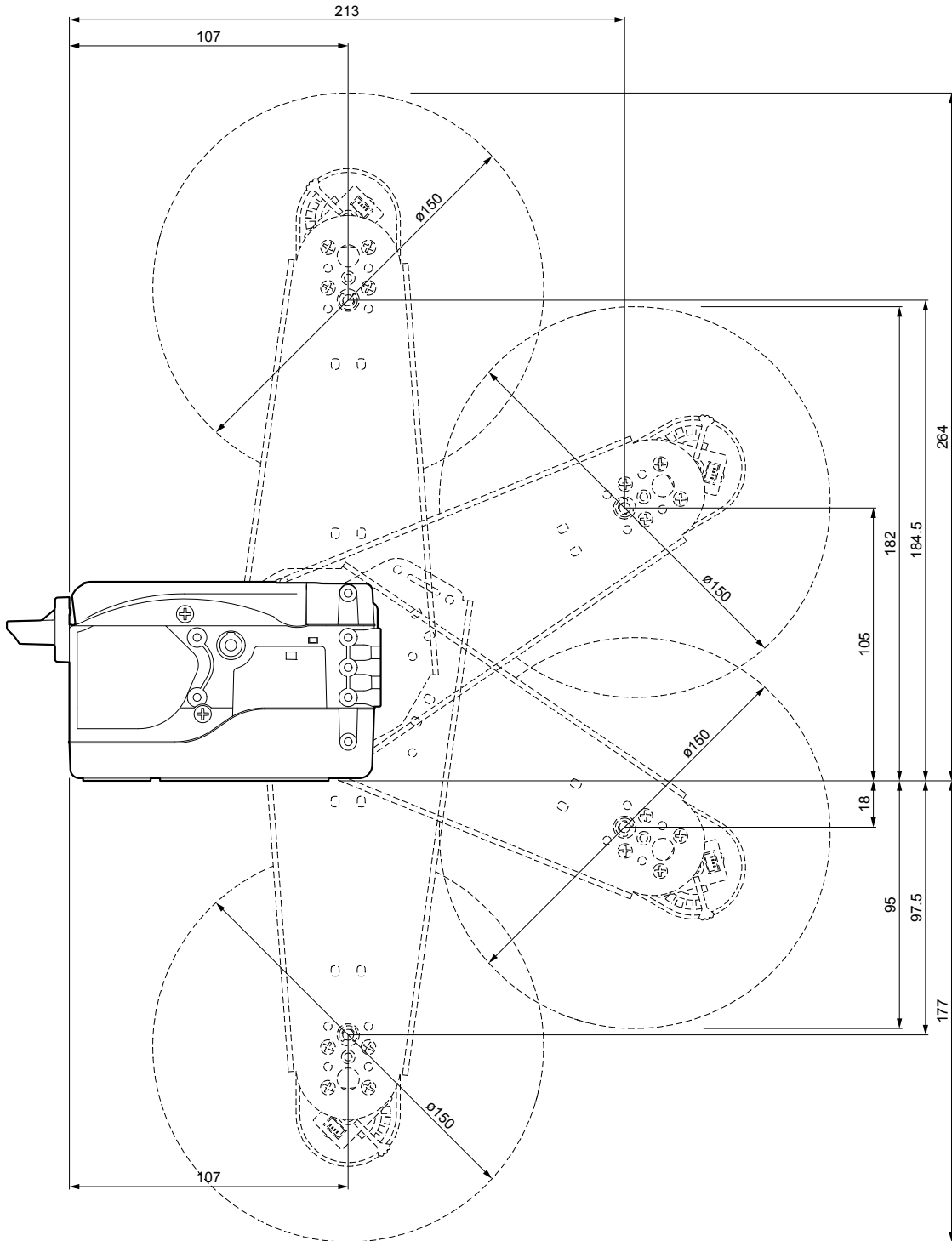



Check the compatibility of the mounting position with the device model:

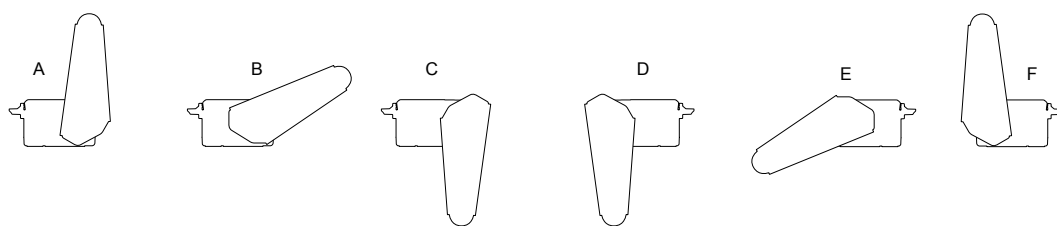

VKP80III RX65 LAT	•	•	•			
VKP80III RX65 REAR	•	•	•	•	•	•
VKP80III ETH	•	•	•			



9.8 Power supply, power cord and adapter for power supply dimensions (optionals)

The following table shows the dimensions of the power supply, the power cord and the adapter for power supply optionals for the device:

POWER CORD code 26100000000311 and code 26100000000313	
Length	2000 mm
ADAPTER FOR POWER SUPPLY code 26900000000005	
Length	200 mm
POWER SUPPLY code 963GE020000071	
Length	130 mm
Height	36 mm
Width	57 mm

All the dimensions shown in following figures are in millimetres.

ADAPTER FOR POWER SUPPLY code 26900000000005

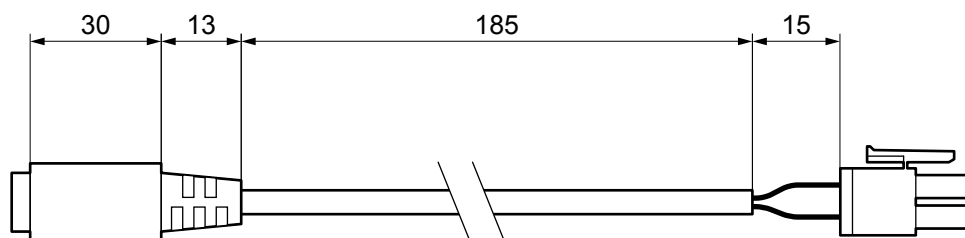

POWER CORD code 26100000000311

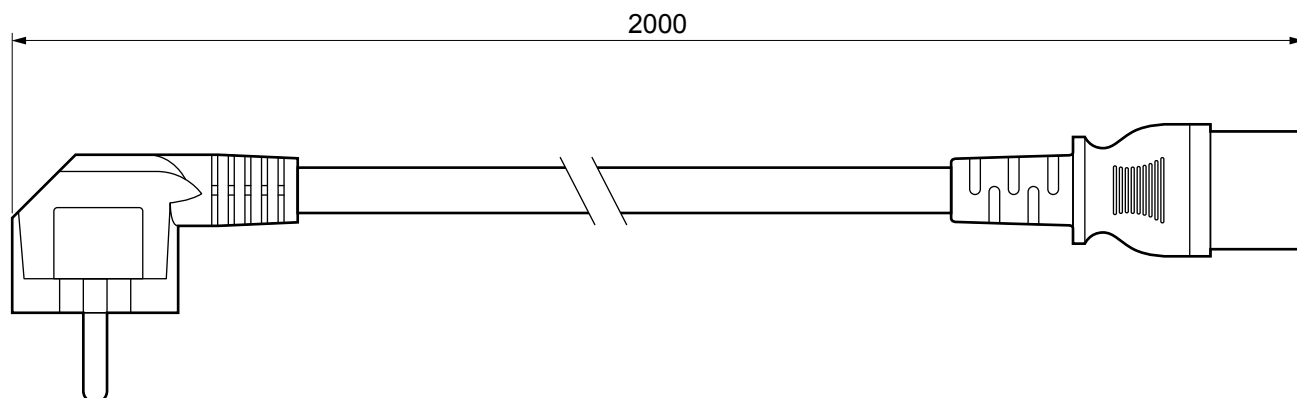



POWER CORD code 26100000000313

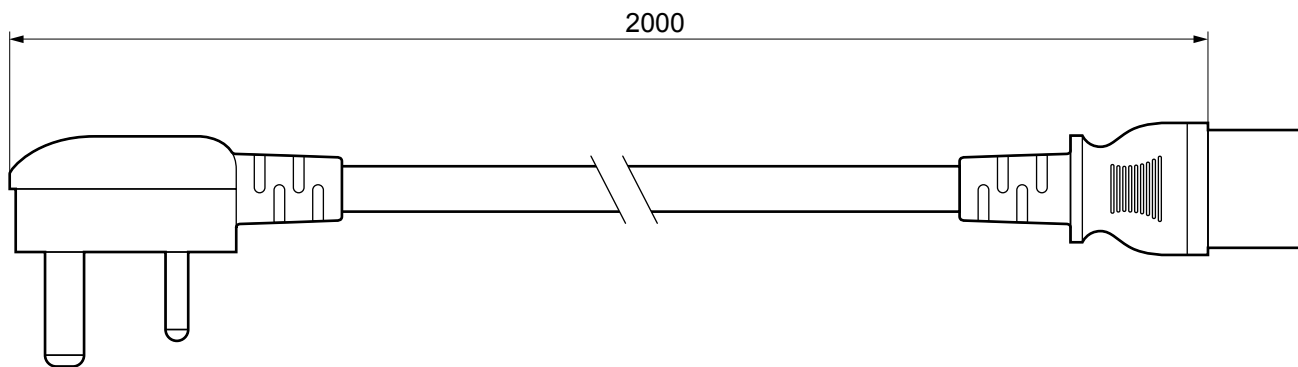

POWER SUPPLY code 963GE020000071

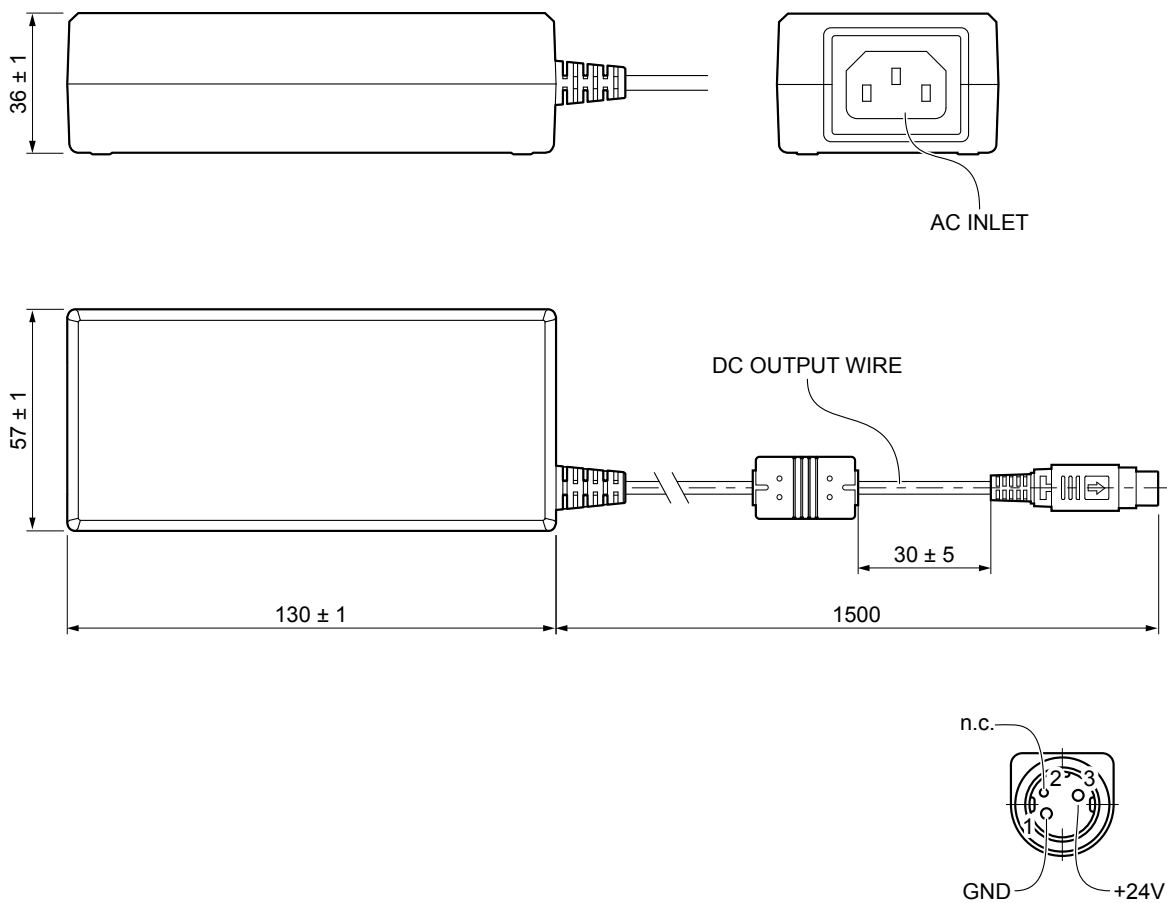

9.9 Paper specification

Paper with black mark on the non-thermal side of paper

The following image shows the placement of the black mark on the non-thermal side of paper. Due to the adjustable mobile sensor, the black mark can be placed anywhere on the whole width of the paper. For more information about the use of paper with black mark see [chapter 7](#).

All the dimensions shown in following figures are in millimetres.

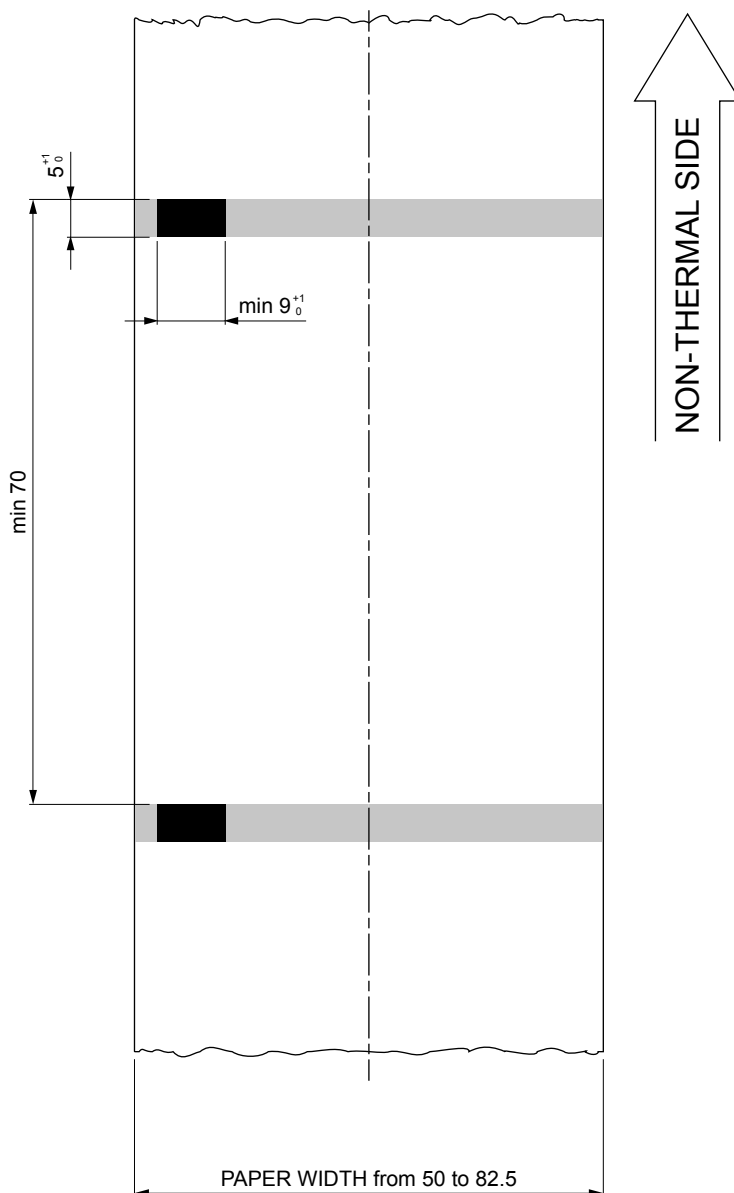

Paper with black mark on the thermal side of paper (only with VKP80III emulation enabled)

The following image shows a sample of paper with the black mark printed on the thermal side. Use this kind of tickets if the upper black mark sensor (optional) is installed on the right paper cursor.

For models with the upper black mark sensor (optional) installed on the left cursor, the ticket will be symmetrical to its longitudinal axis.

For more information about the use of tickets with black mark see [chapter 7](#).

All the dimensions shown in following figures are in millimetres.

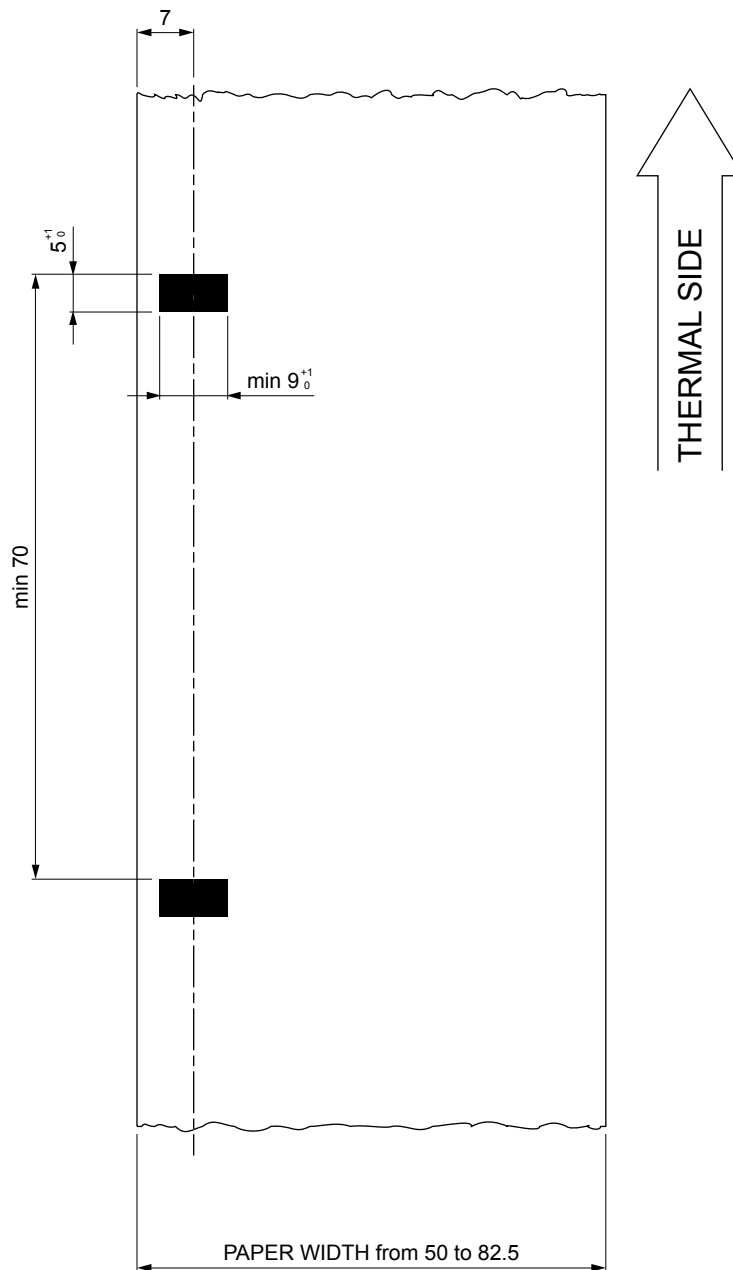



9.10 Character sets

The device has 3 fonts of varying width (11, 15 and 20 cpi) which may be related one of the coding tables provided on the device.

To know the coding tables actually present on the device, you need to print the font test (see [paragraph 3.5](#)).

You can set font and coding table by using the commands (see the commands manual of the device) or using the “Code Table” and the “Chars / Inch” parameters during the setup procedure (see [paragraph 6.7](#)).

The following is the full list of coding tables that can be installed on the device.

<CodeTable>	Character tables	
0	PC437 - U.S.A., Standard Europe	
1	Katakana	
2	PC850 - Multilingual	
3	PC860 - Portuguese	
4	PC863 - Canadian/French	
5	PC865 - Nordic	
6	VISCII - Vietnamese Standard Code	
7	Iran system	
11	PC851 - Greek	on request
12	PC853 - Turkish	on request
13	PC857 - Turkish	
14	PC737 - Greek	
15	ISO8859-7 - Greek	on request
16	WPC1252 - Scandinavian	on request
17	PC866 - Cyrillic 2	
18	PC852 - Latin 2	
19	PC858 (for Euro symbol in position 2013)	
20	KU42 - Thai	
21	TIS11 - Thai	on request
26	TIS18 - Thai	on request
30	TCVN_3 - Vietnamese	on request
31	TCVN_3 - Vietnamese	on request
32	PC720 - Arabic	on request



33	WPC775 - Baltic Rim	on request
34	PC855 - Cyrillic	
35	PC861 - Icelandic	on request
36	PC862 - Hebrew	
37	PC864 - Arabic	on request
38	PC869 - Greek	on request
39	ISO8859-2 - Latin 2	on request
40	ISO8859-15 - Latin 9	on request
41	PC1098 - Farci	
42	PC1118 - Lithuanian	on request
43	PC1119 - Lithuanian	on request
4	PC1125 - Ukrainian	
45	WPC1250 - Latin 2	
46	WPC1251 - Cyrillic	
47	WPC1253 - Greek	
48	WPC1254 - Turkish	
49	WPC1255 - Hebrew	
50	WPC1256 - Arabic	
51	WPC1257 - Baltic Rim	
52	WPC1258 - Vietnamese	
53	KZ1048 - Kazakh	on request
255	Space page	



9.11 True Type fonts

In VKP80III emulation, it is possible to use TrueType fonts. To be used, a TrueType font must be monospace type (every character of the font must have the same dimension). The check is made by the device when the font is selected.

TrueType fonts will be automatically scaled by the device in order to obtain the same available width for the embedded fonts (11, 15 and 20 cpi).

The quality of TrueType fonts, the correct positioning into the printable area and the available code tables, will result from the font producers and the font implementation.

For the correct printing of the code tables, it is necessary that the selected TrueType font contains all the characters in the tables. Otherwise, the '□' symbol will be printed instead the missing character. All commands for printing configuration are usable both with TrueType fonts and with embedded fonts. It is possible to address the TrueType font respects the UNICODE™ standard (see www.unicode.org), by using UTF-8 or UTF-16 encoding.



10 CONSUMABLES

The following table shows the list of available consumables for device:

6730000000401

THERMAL PAPER ROLL

weight = 74 g/m²

width = 80 mm

Ø external = 80 mm

Ø core = 25 mm

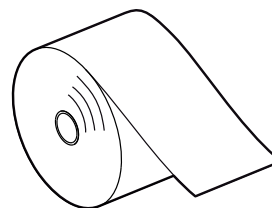



11 ACCESSORIES

The following table shows the list of available accessories for device:

963GE020000071

POWER SUPPLY
(for technical specifications, see [paragraph 9.1](#))

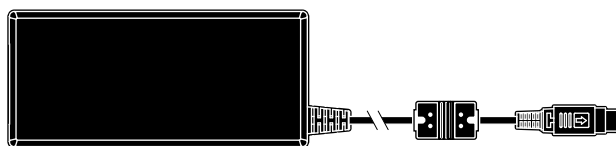

26100000000311

POWER CORD SCHUKO PLUG
length = 2 m
(see [paragraph 9.8](#))

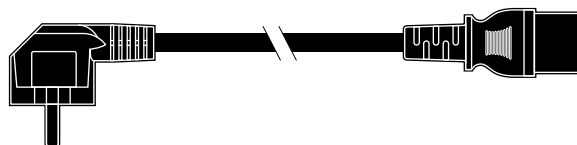

26100000000313

POWER CORD UK PLUG
length = 2 m
(see [paragraph 9.8](#))

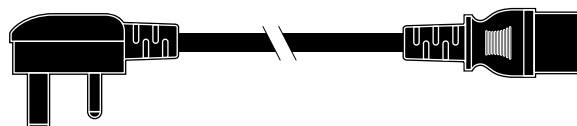

26900000000005

ADAPTER CABLE FOR POWER SUPPLY
length = 200 mm
(see [paragraph 9.8](#))



976DX010000002

STARTER KIT

POWER SUPPLY CABLE
length = 1 m

+
SERIAL CABLE RS232-DB9F
length = 97 mm

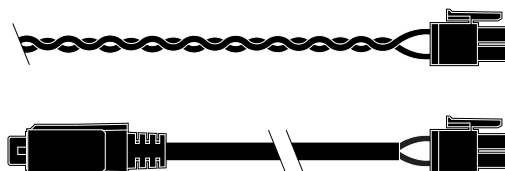



976DX010000004

EXTERNAL LOW PAPER SENSOR
board with cable 230 mm long

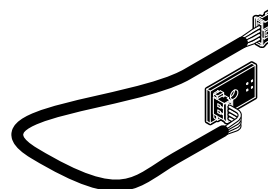

974DX010000001

PAPER ROLL HOLDER WITH BRACKET AND
LOW PAPER SENSOR
to assemble on the right or left side of the device
(see [paragraph 9.6](#) and [paragraph 9.7](#))

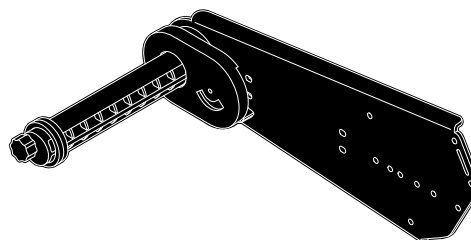

974DX010000005

PAPER ROLL HOLDER WITH
LOW PAPER SENSOR

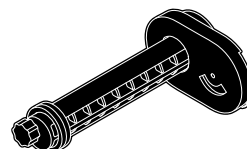

976DX010000008

SHUTTER DEVICE

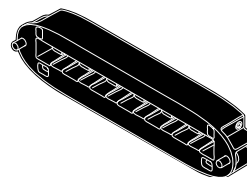



12 TECHNICAL SERVICE

In case of failure, contact the technical service accessing the website www.custom4u.it and using the support tools on the homepage. It is advisable to keep the identification data of the product at hand.

The product code, the serial number and the hardware release number can be found on the product label (see [paragraph 3.4](#)).

The firmware release number (SCODE) can be found:

- on the setup report (see [paragraph 6.2](#))
- connecting the device to a PC and starting the "PrinterSet" tool (see [paragraph 6.1](#))
- by consulting the "setup.ini" file (see [paragraph 6.3](#))

CUSTOM[®]

CUSTOM S.p.A.

World Headquarters

Via Berettine, 2/B - 43010 Fontevivo, Parma ITALY

Tel. +39 0521 680111 - Fax +39 0521 610701

info@custom.biz - www.custom.biz

All rights reserved