

HIKVISION

ABM: Camera Bracket

General Information/Key Features

- UPC: 0816783019500
- UNSPSC: 31162506
- Harmonization Code: 8529904900
- Country of Origin: US

Related Pages (Right click to open in new tab)

Shop Now. Visit the [ABM](#) product page for detailed information

View [other Hikvision Camera Brackets](#)

View over 1300 [video surveillance products from Hikvision](#)

Scroll down to view the Hikvision ABM specification sheet



HIKVISION
ABM

<https://www.surveillance-video.com> is a distributor/reseller of over 120,000 security products from over 100 brands.

For over 45 years, we have earned the confidence of our customers by providing professional service and support.

If you need technical support or assistance to install your security system or any other products purchased from Surveillance-video.com, you can call us @ **800-955-5201** at any time.

ABM

Inclined Ceiling Mount Bracket for Dome Camera



	ABM
Appearance	Hikvision white
Materials	Aluminum alloy
Dimensions	Φ157 mm x 65.5 mm (6.18" x 2.58")
Weight	586 g (20.67 ozs)

NOTE: Install bracket on flat wall.

Key Features

- Aluminum Alloy with Surface Spray Treatment
- Waterproof

Waterproof rubber is necessary for outdoor application.

The wall must be capable of supporting over three times as much as the total weight of the camera and the mount.

The maximum load capacity of the bracket is 4.5 kg (9.92 lbs).

Dimensions

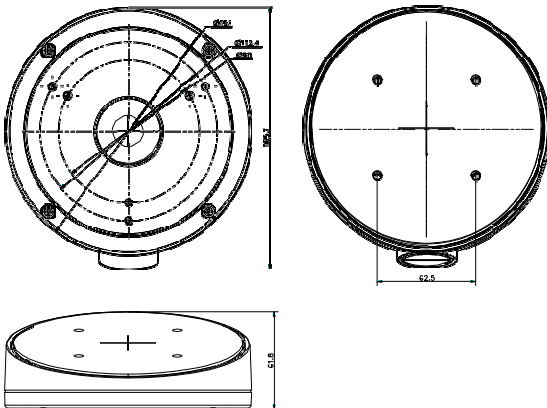

NOTE: The actual dome camera may vary from the picture above.

Order Model

ABM